

# Nema 34

2 phase 1.8° step angle  
 hybrid stepping motor

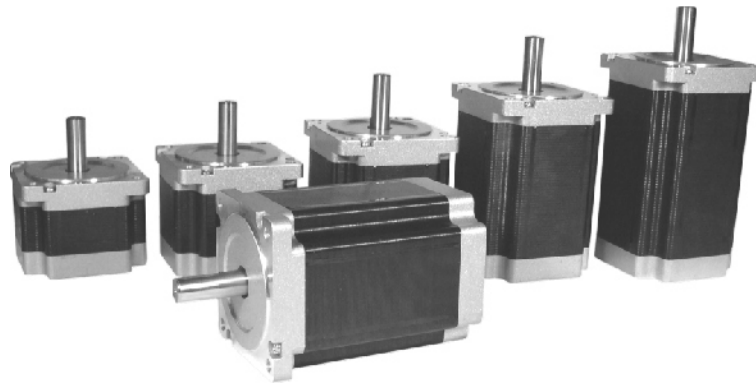

Specifications:

Model	Holding Torque (Nm)	Phase current (A)	Rotor Inertia (g/cm <sup>2</sup> )	Motor Length L max (mm)	Detent Torque (Nm)	Phase Resistance (ohm)	Phase Inductance (mH)	Lead Wire (No)	Motor Weight (Kg)	Note
<b>M1343011</b>	3.1	5.6	850	66	0.055	0.26	1.5	8	1.9	Bip. parallel
<b>M1343020</b>	4.4	5.6	1050	78	0.065	0.35	2.8	8	2.3	Bip. parallel
<b>M1343021</b>	4.4	7.1	1050	78	0.065	0.21	1.6	8	2.3	Bip. Parallel
<b>M1343031</b>	6.8	7.1	1550	98	0.095	0.26	2.2	8	3	Bip. Parallel
<b>M1343041</b>	8.1	7.1	1800	114	0.13	0.38	3.2	8	3.8	Bip. parallel
<b>M1343050</b>	9.2	7.1	2200	126	0.19	0.43	3.4	8	4.1	Bip. parallel
<b>M1343051</b>	9.2	10	2200	126	0.19	0.18	1.6	8	4.1	Bip. Parallel
<b>M1343060</b>	12.1	10	2500	150	0.25	0.21	2.2	8	5	Bip. Parallel
<b>M1343061</b>	12.1	12	2500	150	0.25	0.17	1.8	8	5	Bip. parallel

Double shaft and custom windings available

Mechanical Dimensions:  
 Unit: mm

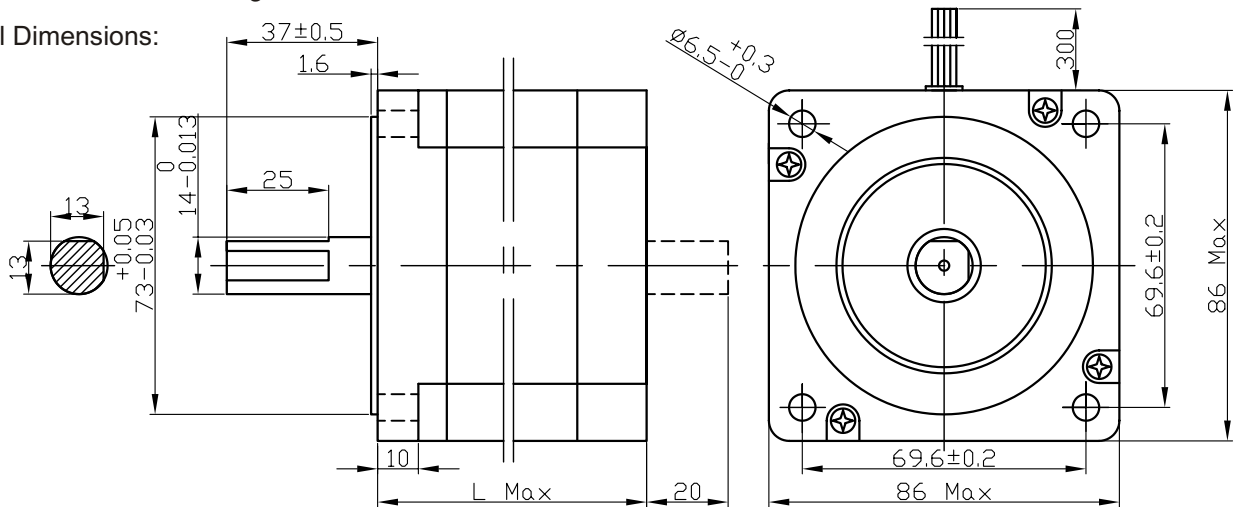

Wiring Diagram:

