



MAX FLOW SIZES
MAX LIQUID PRESSURE
MAX LIQUID PRESSURE

From 5 GPH to 30 GPM (20 LPH to 110 LPM)
 500 PSI (34.48 Bar) or
 1500 PSI (103.42 BAR)
 1% FS accuracy available (1 GPM and higher)

PI 1/4 to 1 inch

UNIVERSAL® Flow Monitors

Piston Inline PI

Flow meters,
Flow switches and
Flow transmitters

Piston - In Line



NIST Traceable Calibration
Certificate Available



PI Series, with standard scale and pointer (control box A).

DESCRIPTION

These variable-area meters position an orifice over a tapered shaft to establish flow rate. Mounting is in-line and in any position. Straight pipe runs before or after this monitor are not required. The all-mechanical sensing system directly drives the pointer, switches and transmitters.

READOUTS

The flowmeter has outputs both visual and electronic. Visual displays are either pointer (with inscribed scale) or numeric (digital LCD). Electronic outputs can be mechanical switch closure, 4-20 mA analog, HART or some combination of switches with electronic outputs (for signal redundancy). The switches can be general purpose or rated for hazardous locations (all classes, groups and divisions).

CALIBRATION

All flow meters are individually calibrated for fluids with the viscosity you specify (up to 3000 SSU/650 Centistokes). We also compensate for your fluid's specific gravity. For NIST Traceability please consult factory.

CONSTRUCTION MATERIALS

Housings and seals are offered in a variety of materials to suit a wide range of applications, such as: water, oil, coolants, paint, solvents and some corrosive fluids. See selections in the "How to Order" section.

LINE CONNECTION

Ports can be threaded or flanged. See selections in the "How to Order" section.

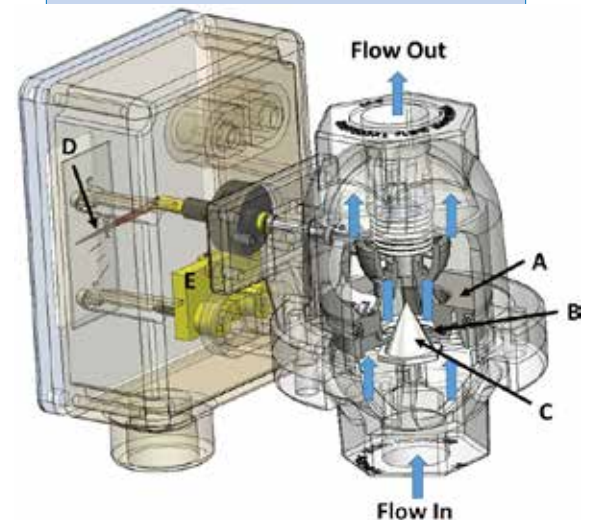

Fluid flow causes a spring-loaded piston **A** having a circular opening at its center **B** to move along the axis of a precision-tapered shaft **C**. This creates a variable orifice in direct proportion to the flow rate. The piston is mechanically linked to the readout pointer **D** and actuates switch **E** or a transmitter (not shown).

EXAMPLE: PI - B Z F 10GM-4 32V1.0 -

SERIES BY PRESSURE RATING	
Piston Inline	= PI

HOUSING MATERIAL 500PSI	WHERE USED	
Aluminum	Lube oil	= A
Brass	Water	= B

HOUSING MATERIAL 1500PSI	WHERE USED	
Stainless steel (316)	Chemicals, corrosives, oil	= Z

INTERNAL MOVING PARTS	
Stainless steel (316L series)	Water, oil, chemicals and corrosives = Z

SEAL MATERIAL	
Buna N	Water, oil = B
Viton	Acids, some caustics = F

MAX FLOW RATE LIQUIDS	SCALES
GPH: 5, 10, 15, 20, 25, 30, 40, 50, 60, 75, 80, 90, 100, 120, 150, 200, 250 & 300	= GH
GPM: 0.25, 0.5, 0.75, 1, 1.5, 2, 2.5, 3, 4, 5, 6, 7, 8, 9, 10, 15, 20 & 30	= GM
LPH: 20, 30, 40, 50, 60, 70, 80, 90, 100, 200, 300, 400, 500, 600, 700, 800, 900 & 1000	= LH
LPM: 5, 10, 15, 20, 25, 30, 35, 40, 50, 60, 70, 75, 80, 90, 100	= LM
CMH: 1, 2, 3, 4, 5, 6	= CMH
GLM: Dual scale - gallons & liters per minute	= GLM
Dual Viscosity	= DGM

NOTE: Dual Scales not available with LCD displays.

THREADED ATTACHMENT						
Pipe size and attachment method	Pipe Size In Inches	NPT	SAE	BSPP	BSPT	Max Flow In GPM
	1/4	2	4T	4BP	4BT	5
	3/8	3	6T	6BP	6BT	10
	1/2	4	8T	8BP	8BT	15
	3/4	6	12T	12BP	12BT	20
	1	8	16T	16BP	16BT	30

FLANGED					
Ex: 2FWCS150RF = 1/4", Welded, Carbon steel, Class 150, Raised Face flange					
Pipe Size In Inches	Attachment	Material	Class	Style	
2 = 1/4"	FW=Welded	CS=Carbon Steel	150	RF=ANSI raised face	
4 = 1/2"			300		
6 = 3/4"					
8 = 1"					

FLUID CHARACTERISTICS
Viscosity number followed by a 'V' (for SSU), 'C' (for centipoise), or 'CS' (for centistokes) followed by the specific gravity. Example: 32V1.0 would indicate a fluid with a viscosity of 32 SSU and specific gravity of 1.0

A61 W L - HT - 5D

SERVICE

Oil and dust tight (Type 12) Available on "A", "L" and "Z" only = N
 Weatherproof (Type 4) Available on all boxes = W
 Weatherproof, corrosion proof (Type 4X) Available on all boxes = X

FLOW DIRECTION

Left to right = R
 Right to left = L
 Up = U
 Down = D

SPECIAL OPTIONS (See explanations below)

High-temp- 400°F (300°F for transmitter options) = HT
 High accuracy (+/-1%) ref. page 4 = HA
 Stainless steel ID tag = ST
 Safety Glass window ref. page 4 = TG
 Wall mounting bracket (Optional brackets are not available with flanged units) = W
 Foot mounting bracket (Optional brackets are not available with flanged units) = F

SWITCH SETTING

No symbol = Lowest possible setting (usually 10% of maximum flow)
 Desired set point is assumed to be in flow units already selected (GM). Give flow rate followed by a "D" for flow going down (flow failure) or a "U" for flow going up.
 Example, 5D indicates a setting of 5 GPM in declining flow.

5D

CONTROL BOX & READOUT



"A", "L" and "Z" Boxes

"A", "L" and "Z" boxes are small, simple and cost effective. Available with analog display, mechanical switches or transmitters (HART or 4-20mA).

A Box L Box Z Box

A, L and Z small control box in the following configurations and materials: Polysulfone	Aluminum	316 SS
4-20 mA transmitter (Intrinsically safe with approved barriers)	AX0	ZX0
HART with programmable switch points	AH0	ZH0
Display only	A0	Z0
One SPDT (3 wire)	A1	Z1
One high vibration SPDT (3 wire)	A1B	Z1B
Two SPDT (3 wire)	A2	Z2
Two high vibration SPDT (3 wire)	A2B	Z2B
One SPDT (4 wire)	A3	Z3
Two SPDT (4 wire)	A4	Z4
One SPDT (3 wire) high temperature	A61	Z61
Two SPDT (3 wire) high temperature	A62	Z62
One SPDT (3 wire) gold contact	A71	Z71
Two SPDT (3 wire) gold contact	A72	Z72
One SPDT (3 wire) hermetically sealed	A53	Z53
Two SPDT (3 wire) hermetically sealed	A54	Z54



"R" Box

"R" box is selected for greater visual resolution. It holds switches (general purpose and hazardous location all classes, groups and divisions) and transmitters (HART or 4-20 mA). Switch (standard service) and transmitter are offered in this control box together when signal redundancy is desired.

R Box

Flow rate display plus:

Display only	R0
One SPDT (3 wire)	R1
One high vibration SPDT (3 wire)	R1B
Two SPDT (3 wire)	R2
Two high vibration SPDT (3 wire)	R2B
One SPDT (4 wire)	R3
Two SPDT (4 wire)	R4
One SPDT (3 wire) high temperature	R61
Two SPDT (3 wire) high temperature	R62
One SPDT (3 wire) gold contact	R71
Two SPDT (3 wire) gold contact	R72

Flow rate display, Hazardous location switches as follows:

One SPDT hazardous location	R7
One DPDT hazardous location	R17
Two SPDT hazardous location	R18
Two DPDT hazardous location	R19

Flow rate display, 4-20 mA transmitter plus switch options as follows:

Display and transmitter only (Intrinsically safe with no switch options with approved barriers)	RX0
One SPDT (3 wire)	RX1
Two SPDT (3 wire)	RX2
One SPDT (4 wire)	RX3
Two SPDT (4 wire)	RX4
One SPDT (3 wire) high temperature	RX61

Flow rate display, HART & 4-20mA output:

Hart protocol is not intrinsically safe	RH0
HART & 4-20mA output only	RH0
One SPDT (3 wire)	RH1
Two SPDT (3 wire)	RH2
One SPDT (4 wire)	RH3
Two SPDT (4 wire)	RH4

T Box

"T" Box

"T" box always has a transmitter (4-20 mA) and can be in combination with a mechanical switch for redundancy. It has two junction boxes to separate wiring for switches and transmitters. The display can be analog or digital LCD.

NOTE: The 4-20mA transmitter with or without the LCD and with NO switches is Intrinsically safe with approved barriers.



Pointer, scale and 4-20 mA:

No switches	TX0
One SPDT (3 wire)	TX1
Two SPDT (3 wire)	TX2
One SPDT (4 wire)	TX3
Two SPDT (4 wire)	TX4
One SPDT (3 wire) high temperature	TX61

Flow rate display, HART & 4-20mA output:

HART protocol is not intrinsically safe	TH0
HART & 4-20mA output only	TH0
One SPDT (3 wire)	TH1
Two SPDT (3 wire)	TH2
One SPDT (4 wire)	TH3
Two SPDT (4 wire)	TH4



LCD readout, 4-20mA with 2 open

collectors:	
No switches	TXL0
One SPDT (3 wire)	TXL1
One SPDT (4 wire)	TXL3
One SPDT (3 wire) high temperature	TXL61

ENGINEERING DATA

Maximum fluid temperature: 200°F (93°C)
Maximum ambient temp: 150°F (65°C) CSA listed only to 105°F (41°C)
Series PI max. operating pressures: (3:1 safety factor): 500 PSI (34.48 BAR) or 1500 PSI (103.42 BAR)
Pressure drop: 5 PSI (.35 BAR) at full scale
Readout accuracy, full scale: ±2%
 1% HA (high accuracy) available on 1 GPM and above.
 Reference Special Options below
Switch repeatability is 1% of actual flow

INSTALLATION

Piston Inline (PI) meters mount in-line and are typically supported by rigid pipe.
 For additional support when using tubing or flexible hose, order special options W (Wall) or F (Foot) mounting brackets.

SPECIAL OPTIONS

High temperature: (option HT) requires all-metal construction with seals of Viton, EPR, Kalrez or Teflon (compatible with fluid). A thermal barrier (heat-resistant cloth) is added between the housing and the control box, which must be used with service option "W" (weatherproof) or "X" (corrosion resistant). A metal scale is provided.

High Accuracy: (option HA) Modification of full scale to +/-1%. HA not available on R7, R17, R18, R19 switch options. Requires flow rates of 1 GPM or greater.

Identification tag: (option ST) customer-supplied information is stamped on a stainless steel tag that is attached to the nameplate.

Safety Glass window: (option TG) replaces the standard window with "Laminated Safety Glass" ANSI Z97.1 and CPSC 1601 CFR 1201.

Foot Mount Bracket

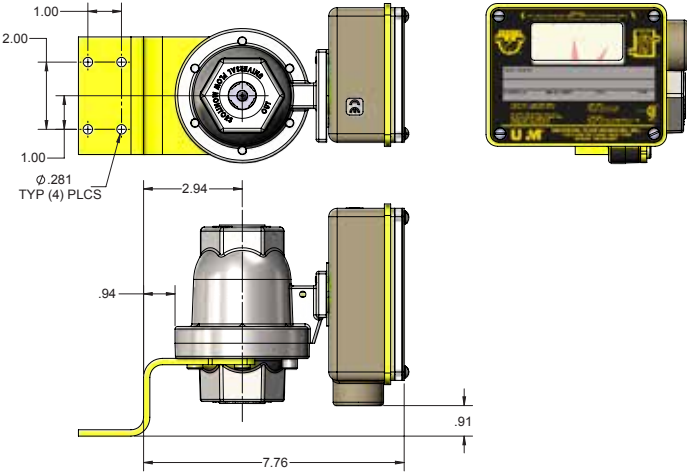

Wall Mount Bracket

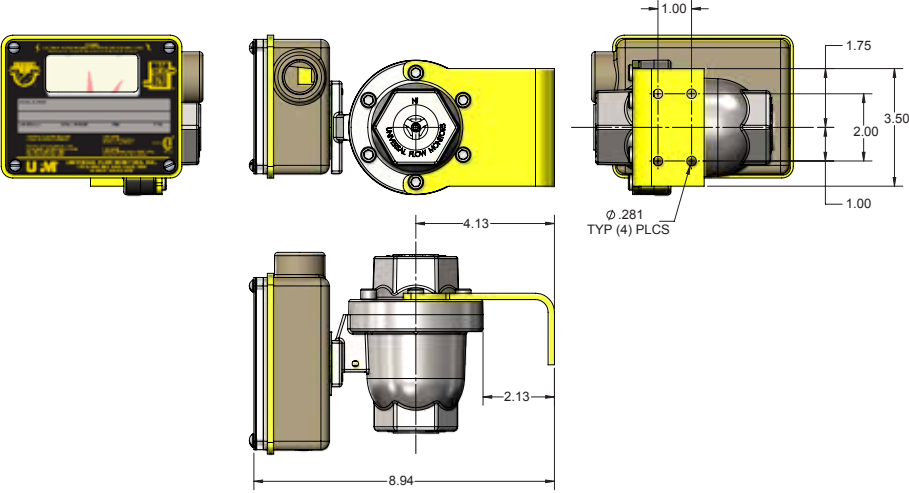

CONTROL BOX SELECTION GUIDE

“A”, “L” and “Z” Boxes

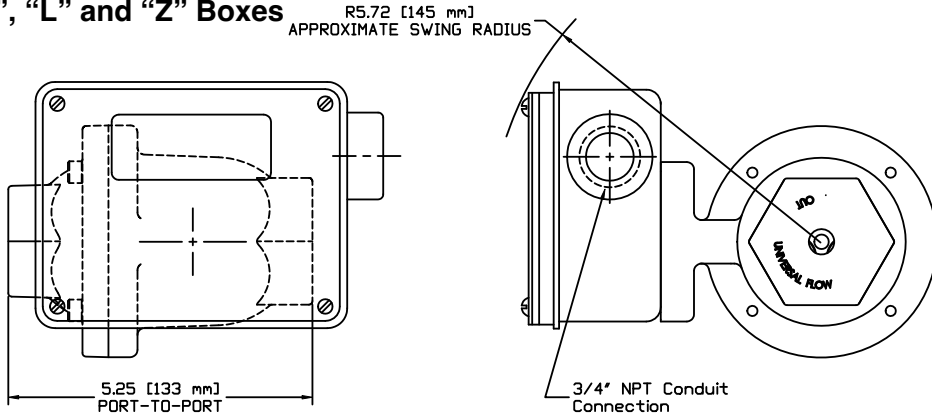

Maximum installation dimensions

“T” Box

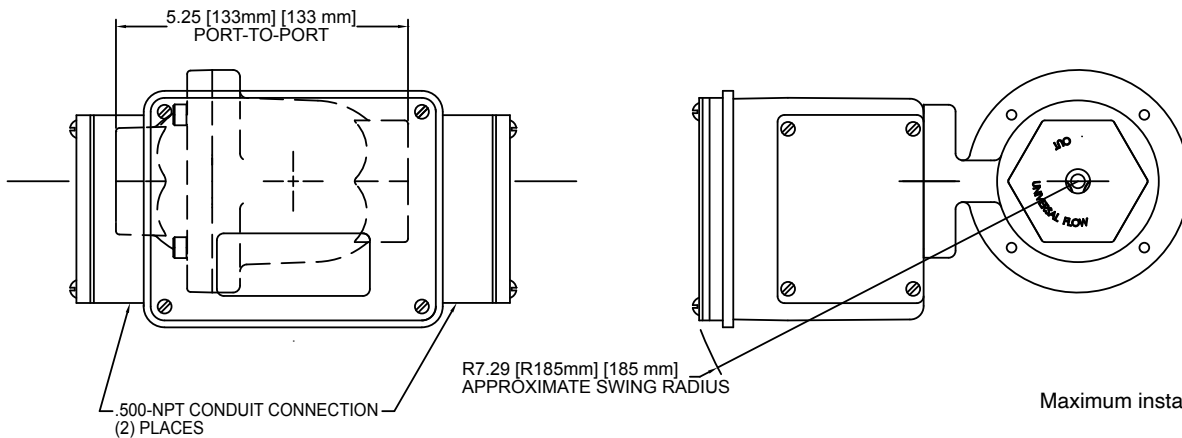

Maximum installation dimensions

“R” Box

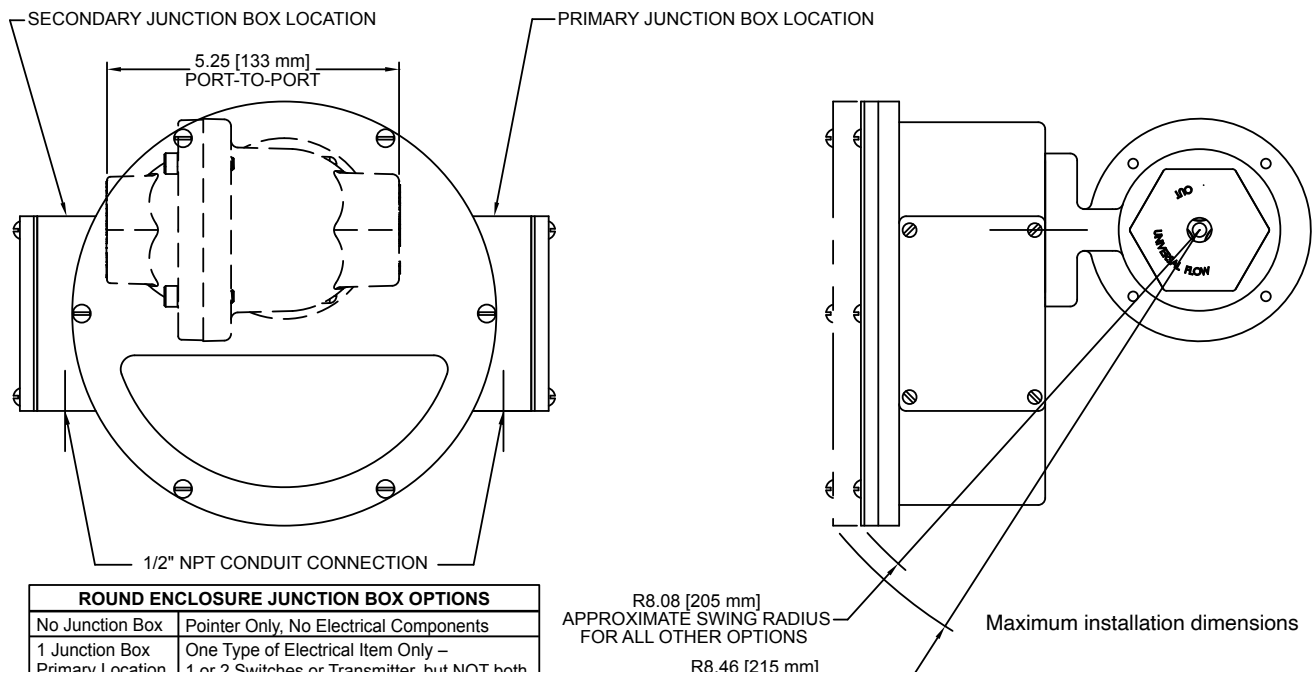

ROUND ENCLOSURE JUNCTION BOX OPTIONS	
No Junction Box	Pointer Only, No Electrical Components
1 Junction Box	One Type of Electrical Item Only –
Primary Location	1 or 2 Switches or Transmitter, but NOT both

R8.08 [205 mm]
APPROXIMATE SWING RADIUS
FOR ALL OTHER OPTIONS

R8.46 [215 mm]

Maximum installation dimensions

A-Box for PI Series w Flanges

Face-to-Face Dimensions With 150# R.F. Flanges

(for other flanges consult factory)

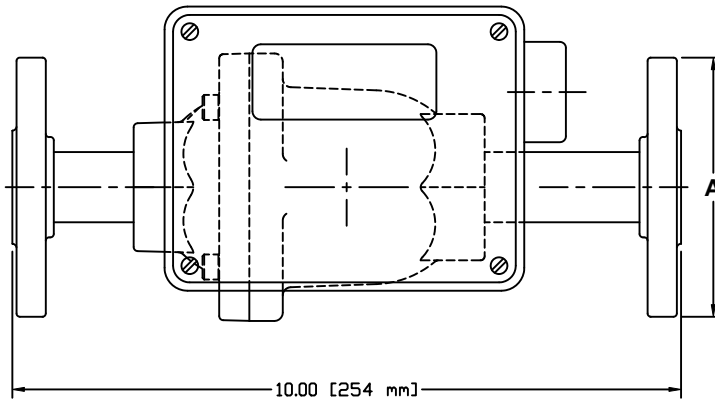

Port Size (Inches)	Dia. A
1/2	3 1/2
3/4	3 7/8
1	4 1/4

"Flow Up" or "Flow Down" dimensions are the same.
Scale numbers are rotated 90° to read correctly.