

FML250™ Data Sheet

UNIVERSAL® Flow Monitors

The FML250 Liquid Flow Monitor is designed specifically for liquid applications to accurately compute and display actual flow parameters. The system operates seamlessly with our TM Series flow meters to deliver quality results for various application requirements.

The FML250 monitor is front keypad programmable, features an LCD display, and allows for 2-40 point linearization for enhanced metering accuracy.

The FML250 can calculate liquid flow in multiple engineering units, including mass, and has selections for flow meter pulse inputs.

This battery-powered monitor can be electronically adjusted to reduce noise, providing optimal accuracy, mobility, and high-precision reliability for liquid monitoring requirements.



FML250 with FM Flowmeter

FML250 Features

Factored Pulse Output: (150mA, 30VDC max)

Opto-isolated open collector output

Frequency or Fixed Pulse Width:

2, 5, 10, 50, 100, 250, 500 & custom mS

Pulse Output Divider:

1, 10, 100, 1000, & custom

Pulse Output Multiplier:

x100(0.01), x10(0.1)

Factored Rate Output: (4-20mA)

+/- 0.3% reading

Scalable low and high programmable

Loop powered operation (7.5-36VDC)

Enclosure Rating: NEMA 4X



Display:

+/- 0.01% reading (rate)

or +/- 1 count (total)

Rate Display: auto-ranging

Input Impedance: 10k ohms

Temperature Compensation:

-328° F to +1,000° F

Accuracy +/- 0.03%

(full scale at 75° F)

Power Modes:

External loop powered and reverse polarity protected

Operating Temperature:

-22° F to +150° F

Signal Input:

0-6000Hz, 50mV-36V (field adjustable)

SPECIFICATIONS

Performance Data

Linearization	2-40 points
Refresh Rate	Continuous to 2 seconds
Pulse Input	Supports sine wave
Keypad	Front panel
Power	Battery powered operation and selectable power modes. Lithium primary D cell battery standard, alkaline 1.5 D clip available
Testing	Built-in test system for diagnostics, pulse output, and 4-20mA output testing
Rate Display Units	Per second, minute, hour, day, or custom
Maintenance	Automatic reminders and flow rate warnings
Materials	
Mounts	Direct turbine, wall, or swivel
Weight	2 lbs
Data Storage	EEPROM parameter storage Secondary storage location for parameters and linearization table

The FML250 Product Family

	Meter Mount (None)	Swivel Mount (SM)	Wall Mount (W)
Options			
Standard Pulse Output	FML250-P	FML250-P-SM	FML250-P-W
4-20mA Loop Output (4)	FML250-P4	FML250-P4-SM	FML250-P4-W
Linearization (2-40 point)	FML250-PL	FML250-PL-SM	FML250-PL-W
Pulse, 4-20mA, Linearization	FML250-P4L	FML250-P4L-SM	FML250-P4L-W
Temperature Compensation	FML250-PTC	FML250-PTC-SM	FML250-PTC-W



Universal Flow Monitors, Inc.

1755 E. Nine Mile Road ▪ P.O. Box 249 ▪ Hazel Park, MI 48030

Tel: 248-542-9635 ▪ Fax: 248-398-4274

www.flowmeters.com



LINE SIZE	1/2 TO 12 INCH	HA SERIES
PRESSURE	5000 PSI	1/2% ACCURATE

Turbine HA

UNIVERSAL® Flow Monitors Ultra-Precise Liquid Flow Measurement

Specifically engineered to meet the strict standards required for custody transfer, the High Accuracy Meter delivers +/- 0.5% accuracy and +/- 0.1 % repeatability for low viscosity applications.

Every flow meter has a unique K-factor and is documented by means of NIST-traceable factory, independent laboratory, or bench calibration processes.



HA HIGH ACCURACY TURBINE

INSTALLATION DRAWING

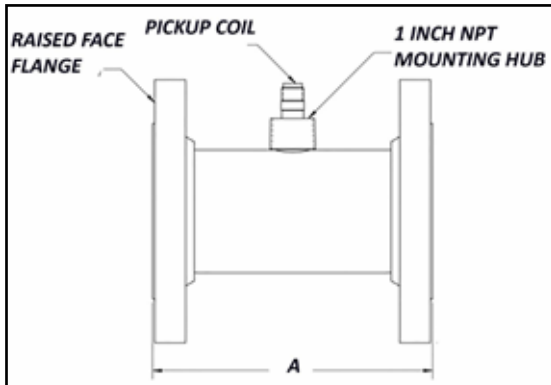

FLANGED HA

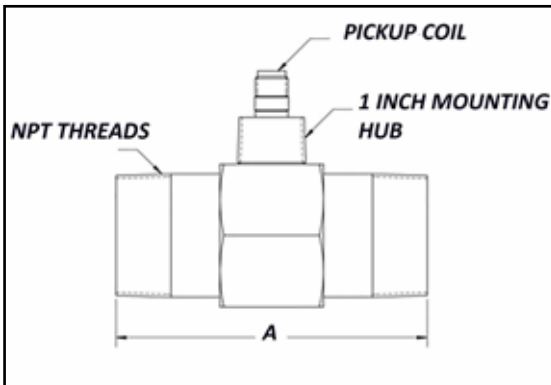

MALE HA

Performance Data

Calibration	+/- 0.5% over standard flow range
Repeatability	+/- 0.1% over standard flow range
Linearity	+/- 0.5% over standard flow range
Operating Temperature	-450° F to +450° F
Connection	NPT or RF Flanged (150 & 300 lb)
Flow Rate	1 to 12000 GPM
Materials	
Meter Body	316 stainless steel
Rotor	17-4PH, Nickel 200
Bearings	Ball Bearing, Tungsten Carbide Sleeve
Certifications	NIST, CRN
Additional Information	Full line of economical Retrofit Kits are available

Installation

1. Magnetic pickup coils included with each turbine meter at no extra charge
2. Turbine meter is linear and accurate over its designed operating range
3. Minimum recommended piping installation: 10 diameters upstream & 5 diameters
4. Locate valves or chokes downstream
5. For best meter performance and to avoid bearing wear, do not exceed maximum rated flow for long periods of time

EXAMPLE 1: HA0050 - N

Part Number	End Connection Size (in)	Flow in GPM		Flow in LPM		A Dimension Inches
		Min	Max	Min	Max	
HA0050	1/2" x 1/2" Male NPT	1	10	4	38	3
HA0050-F150	1/2" x 1/2" with 150 LB RF flange	1	10	4	38	5
HA0050-F300	1/2" x 1/2" with 300 LB RF flange	1	10	4	38	5
HA0075	3/4" x 3/4" Male NPT	2.5	30	9	110	3.25
HA0075-F150	3/4" x 3/4" with 150 LB RF flange	2.5	30	9	110	5.5
HA0075-F300	3/4" x 3/4" with 300 LB RF flange	2.5	30	9	110	5.5
HA0100	1" X 1" Male NPT	4	60	15	225	3.5
HA0100-F150	1" X 1" with 150 LB RF flange	4	60	15	225	5.5
HA0100 -F300	1" X 1" with 300 LB RF flange	4	60	15	225	5.5
HA0125	1 1/4" X 1 1/4" Male NPT	6	93	23	350	3.875
HA0125-F150	1 1/4" X 1 1/4" with 150 LB RF flange	6	93	23	350	6
HA0125 -F300	1 1/4" X 1 1/4" with 300 LB RF flange	6	93	23	350	6
HA0150	1 1/2" X 1 1/2" Male NPT	8	130	30	490	4.375
HA0150-F150	1 1/2" X 1 1/2" with 150 LB RF flange	8	130	30	490	6
HA0150 -F300	1 1/2" X 1 1/2" with 300 LB RF flange	8	130	30	490	6
HA0200	2" X 2" Male NPT	15	225	55	850	4.75
HA0200-F150	2" X 2" with 150 LB RF flange	15	225	55	850	6.5
HA0200 -F300	2" X 2" with 300 LB RF flange	15	225	55	850	6.5
HA0300	3" x 3" Male NPT	40	650	150	2460	10
HA0300-F150	3" x 3" with 150 LB RF flange	40	650	150	2460	10
HA0300 -F300	3" x 3" with 300 LB RF flange	40	650	150	2460	10
HA0400-F150	4" x 4" with 150 LB RF flange	75	1250	280	4700	12
HA0400 -F300	4" x 4" with 300 LB RF flange	75	1250	280	4700	12
HA0600-F150	6" x 6" with 150 LB RF flange	200	2900	750	11000	14
HA0600 -F300	6" x 6" with 300 LB RF flange	200	2900	750	11000	14
HA0800-F150	8" X 8" with 150 LB RF flange	330	5200	1250	19700	16
HA0800 -F300	8" X 8" with 300 LB RF flange	330	5200	1250	19700	16
HA1000-F150	10" x 10" with 150 LB RF flange	650	8000	2500	30300	20
HA1000 -F300	10" x 10" with 300 LB RF flange	650	8000	2500	30300	20
HA1200-F150	12" x 12" with 150 LB RF flange	900	12000	3400	45500	24
HA1200 -F300	12" x 12" with 300 LB RF flange	900	12000	3400	45500	24

STANDARD OUTPUTS WITH NO DIGITAL VISUAL OR PROGRAMMABLE FLOW MONITOR	SYMBOL
Standard mag pickup sine wave good to 30 ft	N
In a Y Enclosure (conduit box)	NY
Hi Temp Magnetic Pick-up (-100F to +450F)	M
In a Y Enclosure (conduit box)	MY
Square wave Magnetic Pick-up with Pre-Amplifier (requires power)	P
In a Y Enclosure (conduit box)	PY
4-20 mA Analog Transmitter in Y Enclosure	X
Want 20 mA at lower than max possible? Express as % of max flow eg. 50% is X50	X50

Note: Y Enclosure is UL rated, Class I, Groups A, B, C & D Class II Groups E, F & G; CSA

EXAMPLE 2: HA0100 - FML250-P-SM

PROGRAMMABLE FLOW MONITOR WITH DIGITAL VISUAL READOUT MOUNTED ON THE FLOW METER		
Added flow meter control box (see FML250 literature) with visual display and programming		
Note: units are pre-set with unit K-factor		
On unit mounting options fixed and on a swivel for better visibility		
Standard Pulse Output	FML250-P	FML250-P-SM
4-20mA Loop Output (4)	FML250-P4	FML250-P4-SM
Linearization (2-40 point)	FML250-PL	FML250-PL-SM
Pulse, 4-20mA, Linearization	FML250-P4L	FML250-P4L-SM
Temperature Compensation	FML250-PTC	FML250-PTC-SM

Note: FML250 Enclosure is NEMA 4 – CSA/UL

Note: Select with your maximum flow at 50% to 100% of the max flow listed above to have sufficient rangeability.

Note: These meters are typically ordered with attached flow monitor display (See FML250 data sheet).
 By putting this FML250 part number at the end of the model selected, it will come installed on the meter and pre-configured for k factor Eg. HA0300-FML250-P-SM.

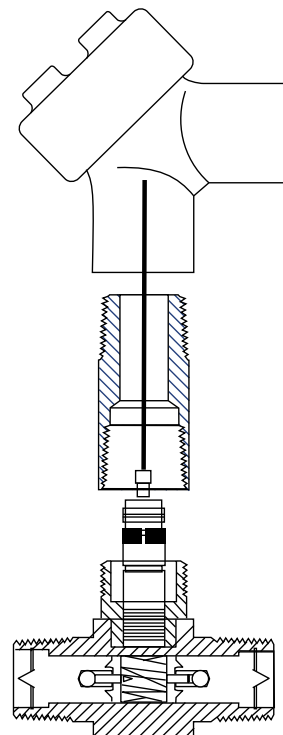

Y ENCLOSURE MOUNTED ON HA METER



FML ENCLOSURE MOUNTED ON HA METER



LINE SIZE
PRESSURE

1/2 TO 12 INCH
5000 PSI

1/2% ACCURATE

TMC Cryogenic Turbine

UNIVERSAL® Flow Monitors

Highly accurate cryogenic flow measurement

The TMC series cryogenic turbine flow meter is specifically engineered for extreme temperature applications. Utilizing an all stainless steel body and shaft, with a nickel rotor, the meter is capable of handling a temperature range of -450°F to 450°F.



TMC TURBINE FOR CRYOGENICS

Performance Data

Calibration	+/- 0.5% over standard flow range
Repeatability	+/- 0.1% over standard flow range
Linearity	+/- 0.5% over standard flow range
Operating Temperature	-450° F to +450° F
Connection	37° AN Flares, NPT or RF Flanged (150 & 300 LB)
Flow Rate	1 to 12000 GPM
Materials	
Meter Body	316 stainless steel
Rotor	Nickel 200
Bearings	Cryogenic grade
Certifications	NIST, CRN, CTOP, NTEP, OIML R81 and R117
Additional Information	Full line of economical Retrofit Kits are available

Installation

1. Magnetic pickup coils included with each turbine meter at no extra charge
2. Turbine meter is linear and accurate over its designed operating range
3. Minimum recommended piping installation: 10 diameters upstream & 5 diameters downstream
4. Locate valves or chokes downstream
5. For best meter performance and to avoid bearing wear, do not exceed maximum rated flow for long periods of time
6. Consult factory for warranty details

INSTALLATION DRAWING

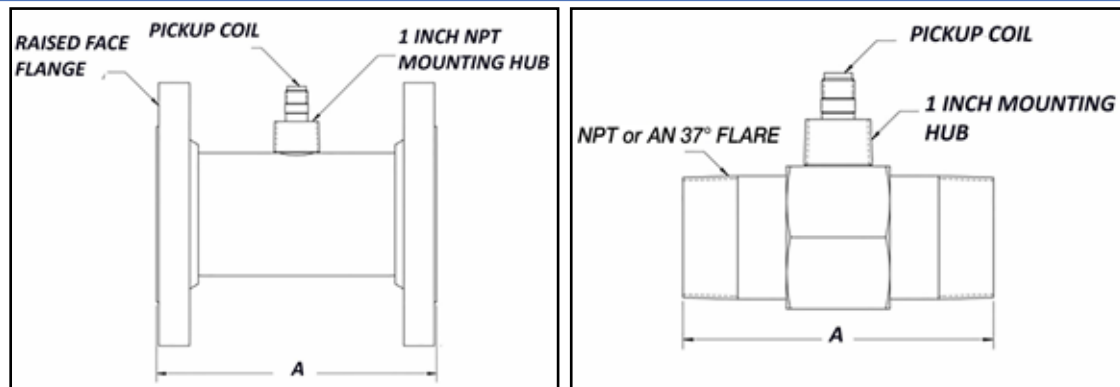

EXAMPLE 1: TMC0050 - N

Part Number	End Connection Size (in)	Flow in GPM		Flow in LPM		A Dimension Inches
		Min	Max	Min	Max	
TMC0050-N	1/2" x 1/2" Male NPT	1	10	4	38	3
TMC0050-F150	1/2" x 1/2" with 150 LB RF Flange	1	10	4	38	5
TMC0050-F300	1/2" x 1/2" with 300 LB RF Flange	1	10	4	38	5
TMC0050-AN	1/2" x 1/2" with AN37 Flare	1	10	4	38	2.56
TMC0075-N	3/4" x 3/4" Male NPT	2.5	30	9	110	3.25
TMC0075-F150	3/4" x 3/4" with 150 LB RF Flange	2.5	30	9	110	5.5
TMC0075-F300	3/4" x 3/4" with 300 LB RF Flange	2.5	30	9	110	5.5
TMC0075-AN	3/4" x 3/4" with AN37 Flare	2.5	30	9	110	3.25
TMC0100-N	1" X 1" Male NPT	4	60	15	225	3.5
TMC0100-F150	1" X 1" with 150 LB RF Flange	4	60	15	225	5.5
TMC0100-F300	1" X 1" with 300 LB RF Flange	4	60	15	225	5.5
TMC0100-AN	1" X 1" with AN37 Flare	4	60	15	225	3.5
TMC0125-N	1 1/4" X 1 1/4" Male NPT	6	93	23	350	3.875
TMC0125-F150	1 1/4" X 1 1/4" with 150 LB RF Flange	6	93	23	350	6
TMC0125-F300	1 1/4" X 1 1/4" with 300 LB RF Flange	6	93	23	350	6
TMC0125-AN	1 1/4" X 1 1/4" with AN37 Flare	6	93	23	350	3.875
TMC0150-N	1 1/2" X 1 1/2" Male NPT	8	130	30	490	4.375
TMC0150-F150	1 1/2" X 1 1/2" with 150 LB RF Flange	8	130	30	490	6
TMC0150-F300	1 1/2" X 1 1/2" with 300 LB RF Flange	8	130	30	490	6
TMC0150-AN	1 1/2" X 1 1/2" with AN37 Flare	8	130	30	490	4.375
TMC0200-N	2" X 2" Male NPT	15	225	55	850	4.75
TMC0200-F150	2" X 2" with 150 LB RF Flange	15	225	55	850	6.5
TMC0200-F300	2" X 2" with 300 LB RF Flange	15	225	55	850	6.5
TMC0200-AN	2" X 2" with AN37 Flare	15	225	55	850	4.75
TMC0300-N	3" x 3" Male NPT	40	650	150	2460	10
TMC0300-F150	3" x 3" with 150 LB RF Flange	40	650	150	2460	10
TMC0300-F300	3" x 3" with 300 LB RF Flange	40	650	150	2460	10
TMC0400-F150	4" x 4" with 150 LB RF Flange	75	1250	280	4700	12
TMC0400-F300	4" x 4" with 300 LB RF Flange	75	1250	280	4700	10
TMC0600-F150	6" x 6" with 150 LB RF Flange	200	2900	750	11000	14
TMC0600-F300	6" x 6" with 300 LB RF Flange	200	2900	750	11000	14
TMC0800-F150	8" X 8" with 150 LB RF Flange	330	5200	1250	19700	16
TMC0800-F300	8" X 8" with 300 LB RF Flange	330	5200	1250	19700	16
TMC1000-F150	10" x 10" with 150 LB RF Flange	650	8000	2500	30300	20
TMC1000-F300	10" x 10" with 300 LB RF Flange	650	8000	2500	30300	20
TMC1200-F150	12" x 12" with 150 LB RF Flange	900	12000	3400	45500	24
TMC1200-F300	12" x 12" with 300 LB RF Flange	900	12000	3400	45500	24

STANDARD OUTPUTS WITH NO DIGITAL VISUAL OR PROGRAMMABLE FLOW MONITOR	SYMBOL
Standard mag pickup sine wave good to 30 ft	N
In a Y Enclosure (conduit box)	NY
4-20 mA Analog Transmitter in Y Enclosure	X
Want 20 mA at lower than max possible? Express as % of max flow eg. 50% is X50	X50

Note: Y Enclosure is UL rated, Class I, Groups A, B, C & D Class II Groups E, F & G; CSA

EXAMPLE 2: TMC0100 - FML250-P-SM

PROGRAMMABLE FLOW MONITOR WITH DIGITAL VISUAL READOUT MOUNTED ON THE FLOW METER		
Added flow meter control box (see FML250 literature) with visual display and programming		
Note: units are pre-set with unit K-factor		
On unit mounting options fixed and on a swivel for better visibility		
Standard Pulse Output	FML250-P	FML250-P-SM
4-20mA Loop Output (4)	FML250-P4	FML250-P4-SM
Linearization (2-40 point)	FML250-PL	FML250-PL-SM
Pulse, 4-20mA, Linearization	FML250-P4L	FML250-P4L-SM
Temperature Compensation	FML250-PTC	FML250-PTC-SM

Note: FML250 Enclosure is NEMA 4 – CSA/UL

Note: Select with your maximum flow at 50% to 100% of the max flow listed above to have sufficient rangeability.

Note: These meters are typically ordered with attached flow monitor display (See FML250 data sheet).

By putting this FML250 part number at the end of the model selected, it will come installed on the meter and pre-configured for k factor Eg. HA0300-FML250-P-SM.

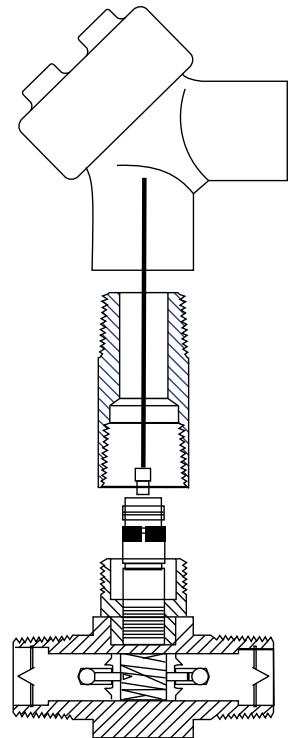

Y ENCLOSURE WITH HUB EXTENDER MOUNTED ON TMC METER



FML ENCLOSURE WITH HUB EXTENDER MOUNTED ON TMC METER



FLOW RANGE	10 TO 3000 GPM (1 TO 2000 LPM)	TM SERIES
PRESSURE	5000 PSI STD 800 PSI VICTAULIC	1% ACCURATE

Turbine™

UNIVERSAL® Flow Monitors Turbine In-Line Meters for Liquids

The TM Series Liquid Turbine flow meter is a highly-versatile product line that offers all stainless steel, precision-machined components with CD4MCu steel rotors. Available for line sizes from 1/2" to 10".



TM FLOWMETER

Performance Data	
Accuracy	+/- 1.0% over flow range (except TM0038 which is +/- 2.0%)
Repeatability	+/- 0.1% over flow range
Operating Temperature	-100° F to +300° F
Connection	Flanged, Victaulic® (grooved), or threaded
Materials	
Meter Body	316 stainless steel
Rotor Supports	316 stainless steel
Meter Rotor	CD4MCu steel
Rotor Shaft	Tungsten carbide
Sleeve Bearings	Tungsten carbide
Certifications	NIST, CRN
Additional Information	Full line of economical Retrofit Kits are available

INSTALLATION DRAWING

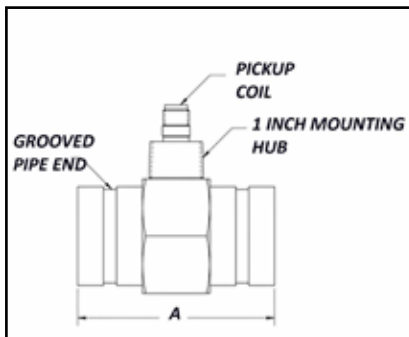

GROOVED VICTAULIC TM

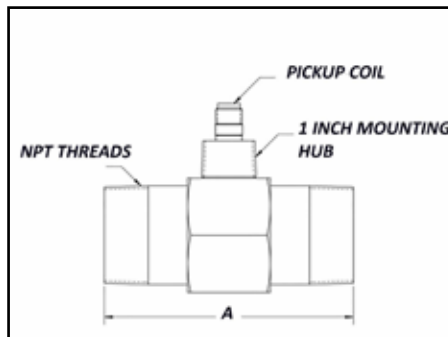

MALE TM

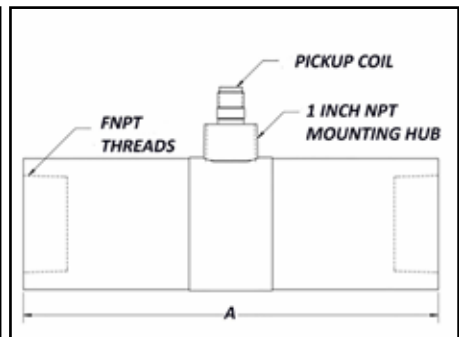

2 INCH FEMALE TM

Installation

1. Magnetic pickup coils included with each turbine meter at no extra charge
2. Turbine meter is linear and accurate over its designed operating range
3. Minimum recommended piping installation: 10 diameters upstream & 5 diameters downstream
4. Locate valves or chokes downstream
5. For best meter performance and to avoid bearing wear, do not exceed maximum rated flow for long periods of time

EXAMPLE 1: TM0050 - N

Part Number	End Connection Size (in)	Flow in GPM		Flow in LPM		A Dimension Inches
		Min	Max	Min	Max	
TM0038	1" X 1" Male NPT	0.3	3	1.1	11	4
TM0038-F150	1" X 1" with 150 LB RF flange	0.3	3	1.1	11	6
TM0038x 1/2	½" X ½" Male NPT	0.3	3	1.1	11	4
TM0050	1" X 1" Male NPT	0.8	8	2.8	28	4
TM0050-F150	1" X 1" with 150 LB RF flange	0.8	8	2.8	28	6
TM0050x 1/2	½" X ½" Male NPT	0.8	8	2.8	28	4
TM0075	1" X 1" Male NPT	2	15	7.6	57	4
TM0075-F150	1" X 1" with 150 LB RF flange	2	15	7.6	57	6
TM0075x 1/2	½" X ½" Male NPT	2	15	7.6	57	4
TM0078	1" X 1" Male NPT	3	30	11.4	114	4
TM0078-F150	1" X 1" with 150 LB RF flange	3	30	11.4	114	6
TM0078-VIC	1" X 1" Victaulic	3	30	11.4	114	4
TM0100	1" X 1" Male NPT	5	50	18.9	189	4
TM0100-F150	1" X 1" with 150 LB RF flange	5	50	18.9	189	6
TM0100-VIC	1" X 1" Victaulic	5	50	18.9	189	4
TM0150	1½" X 1½" Male NPT	15	180	57	681	6
TM0150-F150	1½" X 1½" with 150 LB RF flange	15	180	57	681	7
TM0150-VIC	1½" X 1½" Victaulic	15	180	57	681	6
TM0200L	2" X 2" Low Flow Male NPT	15	180	57	681	6
TM0200L-F150	2" X 2" Low Flow with 150 LB RF flange	15	180	57	681	6.5
TM200L-VIC	2" X 2" Low Flow Victaulic	15	180	57	681	6
TM0200	2" X 2" Female NPT	40	400	151	1514	10
TM0200-F150	2" X 2" with 150 LB RF flange	40	400	151	1514	8.5
TM0300-VIC	3" Victaulic	60	600	227	2271	12
TM0300-F150	3" with 150 LB RF flange	60	600	227	2271	10
TM0400-VIC	4" Victaulic	120	1200	454	4542	12
TM0400-F150	4" with 150 LB RF flange	120	1200	454	4542	12
TM0600-VIC	6" Victaulic	250	2500	946	9464	12
TM0600-F150	6" with 150 LB RF flange	250	2500	946	9464	12
TM0800-VIC	8" Victaulic	350	3500	1325	13249	12
TM0800-F150	8" with 150 LB RF flange	350	3500	1325	13249	12
TM1000-VIC	10" Victaulic	550	5500	2082	20820	12
TM1000-F150	10" with 150 LB RF flange	550	5500	2082	20820	12

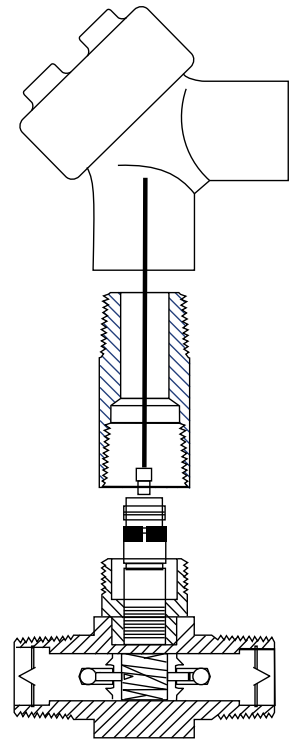

Y ENCLOSURE MOUNTED ON TM METER



FML ENCLOSURE MOUNTED ON TM METER

STANDARD OUTPUTS WITH NO DIGITAL VISUAL OR PROGRAMMABLE FLOW MONITOR

	SYMBOL
Standard mag pickup sine wave good to 30 ft	N
In a Y Enclosure (conduit box)	NY
Hi Temp Magnetic Pick-up (-100F to +450F)	M
In a Y Enclosure (conduit box)	MY
Square wave Magnetic Pick-up with Pre-Amplifier (requires power)	P
In a Y Enclosure (conduit box)	PY
4-20 mA Analog Transmitter in Y Enclosure	X
Want 20 mA at lower than max possible? Express as % of max flow eg. 50% is X50	X50

Note: Y Enclosure is UL rated, Class I, Groups A, B, C & D Class II Groups E, F & G; CSA

EXAMPLE 2: TM0100 - FML250-P-SM

PROGRAMMABLE FLOW MONITOR WITH DIGITAL VISUAL READOUT MOUNTED ON THE FLOW METER

Added flow meter control box (see FML250 literature) with visual display and programming

Note: units are pre-set with unit K-factor

On unit mounting options fixed and on a swivel for better visibility

Standard Pulse Output	FML250-P	FML250-P-SM
4-20mA Loop Output (4)	FML250-P4	FML250-P4-SM
Linearization (2-40 point)	FML250-PL	FML250-PL-SM
Pulse, 4-20mA, Linearization	FML250-P4L	FML250-P4L-SM
Temperature Compensation	FML250-PTC	FML250-PTC-SM

Note: FML250 Enclosure is NEMA 4 – CSA/UL

Note: Select with your maximum flow at 50% to 100% of the max flow listed above to have sufficient rangeability. Select by flow rate with user estimated Max Flow at midscale of max flow for the model so that there is sufficient rangeability for the meter, eg TM0050 for flows between 4 and 8 max.

Note: These meters are typically ordered with attached flow monitor display (See FML250 data sheet). By putting this FML250 part number at the end of the model selected, it will come installed on the meter and pre-configured for k factor Eg. TM0300-FML250-P-SM.



Model FML250

Flow Monitor for LIQUID Applications

U N I V E R S A L



F L O W M O N I T O R S

1796 East 9 Mile Road
Hazel Park, MI 48030
(248) 398-4274
www.flowmeters.com

Copyright 2013-2017 Universal Flow Monitors, Inc. All rights reserved.
Information contained herein is subject to change at any time without prior notice.

Notice

Proprietary Notice

The information contained in this publication is derived in part from proprietary data and trade secrets. This information has been prepared for the expressed purpose of assisting operating and maintenance personnel in the efficient use of the instrument described herein. Publication of this information does not convey any rights to use or reproduce it or to use for any purpose other than in connection with the installation, operation, and maintenance of the equipment described herein.

Copyright 2017

Printed in USA. All Rights Reserved.

SAFETY INSTRUCTIONS

The following instructions must be observed.

- Every effort has been made to design and manufacture this instrument to be safe for its intended use. A hazardous situation may occur if this instrument is not used for its intended purpose or is used incorrectly. Please note operating instructions provided in this manual.
- The instrument must be installed, operated, and maintained by personnel who have been properly trained. Personnel must read and understand this manual prior to installation and/or operation of the instrument.
- The manufacturer assumes no liability for damage caused by incorrect use of the instrument or for modifications or changes made to the instrument.
- The safety of any system incorporating the equipment is the responsibility of the assembler of the system.
- Apart from the batteries, there are no other user serviceable parts.

Les instructions suivantes doivent être respectées.

- Tous les efforts ont été faits pour concevoir et fabriquer cet instrument est sans danger pour son utilisation prévue. Une situation dangereuse peut se produire si cet instrument n'est pas utilisé conformément à sa destination ou est mal utilisé. S'il vous plaît respecter les instructions fournies dans ce manuel.
- L'appareil doit être installé, utilisé et entretenu par du personnel ayant reçu une formation adéquate. Le personnel doit lire et comprendre ce manuel avant l'installation et / ou le fonctionnement de l'instrument.
- Le fabricant décline toute responsabilité pour les dommages causés par une utilisation incorrecte de l'instrument ou de modifications ou de changements apportés à l'instrument.
- La sécurité de tout système intégrant l'équipement est de la responsabilité de l'assembleur du système.
- Outre les piles, il n'y a pas d'autres pièces réparables par l'utilisateur.

Technical Improvements

Universal Flow Monitors may modify the technical data herein without notice.

Table of Contents

Description.....	1
Features:.....	1
Specifications.....	2
Dimensional.....	3
Wiring.....	4
Wiring Guidelines.....	4
Parameters for Intrinsic Safe Installations.....	Error! Bookmark not defined.
Maintenance and Service.....	4
Enclosure.....	4
Batteries and Battery Installation.....	5
Connections.....	6
FML250 wiring.....	7
Wiring the FML250 with HART Adapter board.....	7
Wiring Examples.....	8
Operation Overview.....	16
Flow Calculations.....	16
Linearization.....	16
Temperature Compensation (optional).....	16
U/M.....	16
Pulse Output.....	16
Warnings.....	17
Alarms.....	17
Display.....	18
Reset.....	18
Power.....	18
Auto-Calibration.....	19
Front Panel Display and Controls.....	20
Menu System.....	22
User Interface.....	22
Navigating the menu:.....	22
Editing a number:.....	23
Menu System Items.....	23
Service Menu.....	37
Main Menu Flowchart.....	39
Fluid Properties.....	43

Description

The FML250 Flow Monitor is a microcontroller based rate / totalizer designed for Liquid Applications. The unit has optional temperature compensation which makes adjustments to the flow calculations as needed with temperature fluctuations. Inputs include pulse and square wave flowmeter inputs. The flowmeter input can be electronically attenuated (in the menu system) to reduce noise. Computations include calculation of liquid flow in several engineering units including mass. An internal 40 point linearizer allows linearization of typically non-linear liquid flow meters and to increase the range of repeatable points outside the normal linear range. Outputs include an LCD display, pulse output, 4-20mA, and various other optional output types.

Features:

- 2-40 point linearizer
- Intrinsically Safe
- Temperature compensation (optional)
- Battery powered operation
- Pulse input supports sine and square type flowmeters
- All features/configuration settings are field programmable
- Two lines of independent display capable of displaying any of several calculated values
- Front panel keypad for Display, Reset, and Factor maintain enclosure integrity
- Built-in test system for diagnostics, pulse output, and 4-20mA output testing
- Comprehensive warning and error reporting system
- Non-resettable “Grand” totalizer
- Pulse output is opto-isolated
- Autoranging Rate display
- Selectable power modes for customized battery life and display refresh

Specifications

- **Display**
 - Upper
 - 8 digit 0.75" (19.05mm) high characters
 - Display item push button scrollable
 - Decimal locations: 0.0000001 to x1000
 - Lower
 - 6 digit 0.75" (19.05mm) high characters
 - Display item time stepped
 - Decimal locations: 0.00001 to x1000
 - Refresh rate: continuous, 1/16s, 1/8s, 1/4s, 1/2s, 1s, & 2s
 - Warnings for: Maintenance due, Flow rate, dead battery, running on battery
- **Power**
 - Internal:
 - Lithium: Primary D cell battery standard
 - Provide backup power when 4-20mA loop/DC powered
 - External 4-20mA Loop:
 - Range: 9.5 to 24 VDC
 - Reverse polarity protected
 - Max Current: 20mA
 - DC powered (Reverse polarity protected):
 - Range: 9.5 to 24 VDC
 - Reverse polarity protected
 - Max Current: 35mA
- **K-Factor range**
 - Pulses per Gallon: 0.0000001 to 99,999,999
- **Signal Input (flow) ***
 - Frequency: 10Hz-6kHz
 - Impedance: 10k ohms
 - Sensitivity(Sine): 50mV-24V p-p
 - Sensitivity(Square): 3.6-24V (50% duty)
- **Engineering Unit Conversions**
 - Pre-programmed units: GAL, CF, LIT, M3, BBL, LB, KG, SCF/GAL, MSCF/GAL, SM3/GAL, & MSM3/GAL*
 - Separate UOM for Total and Rate available
 - Custom units available based on GAL
 - */GAL Gas equivalent for cryogenic liquids
- **Compensation**
 - Linearizer table 2 to 40 points
 - Temperature compensation using thermal expansion coefficient calculation (optional 2-wire RTD)
- **Time Base**
 - Rates can be displayed per second, minute, hour, day, and custom (based on seconds)
- **Outputs**
 - Factored Pulse (50mA, 30VDC max)
 - Opto-isolated open collector output
 - Output pulse: Frequency or fixed pulse width: 2, 5, 10, 50, 100, 250, 500, & custom ms
 - Pulse Output Divider: 0.01(x100), 0.1(x10), 1, 10, 100, 1000, & custom
 - Factored Rate (4-20mA)
 - Scalable low and high programmable
- **Error**
 - Display: $\pm 0.01\%$ reading (rate) or ± 1 count (total)
 - Digital output: ± 1 pulse
 - Analog output: $\pm 0.3\%$ reading (rate)
 - Temperature: $\pm 0.03\%$ fs @ 25°C
- **Compliance**
 - CSA/US: Intrinsically Safe: Ia, iic, T4
 - Pollution Degree: 2
 - Overvoltage Category: I
 - Altitude: 2000 m max
 - Enclosure to 4X
- **Environmental**
 - Operating: -30 to 65°C (-22 to 150°F)
 - Storage: -40 to 85°C (-40 to 185°F)
- **Enclosure**
 - Glass filled polycarbonate
 - Weight: 2 lbs.
 - Mount:
 - Turbine (1" NPT)
 - Wall
 - Pedestal
- **Other features**
 - EEPROM parameter storage
 - All parameters are field programmable via front panel push buttons for fast menu navigation and parameter entry

- Secondary storage location for parameters and linearizer table

Dimensional

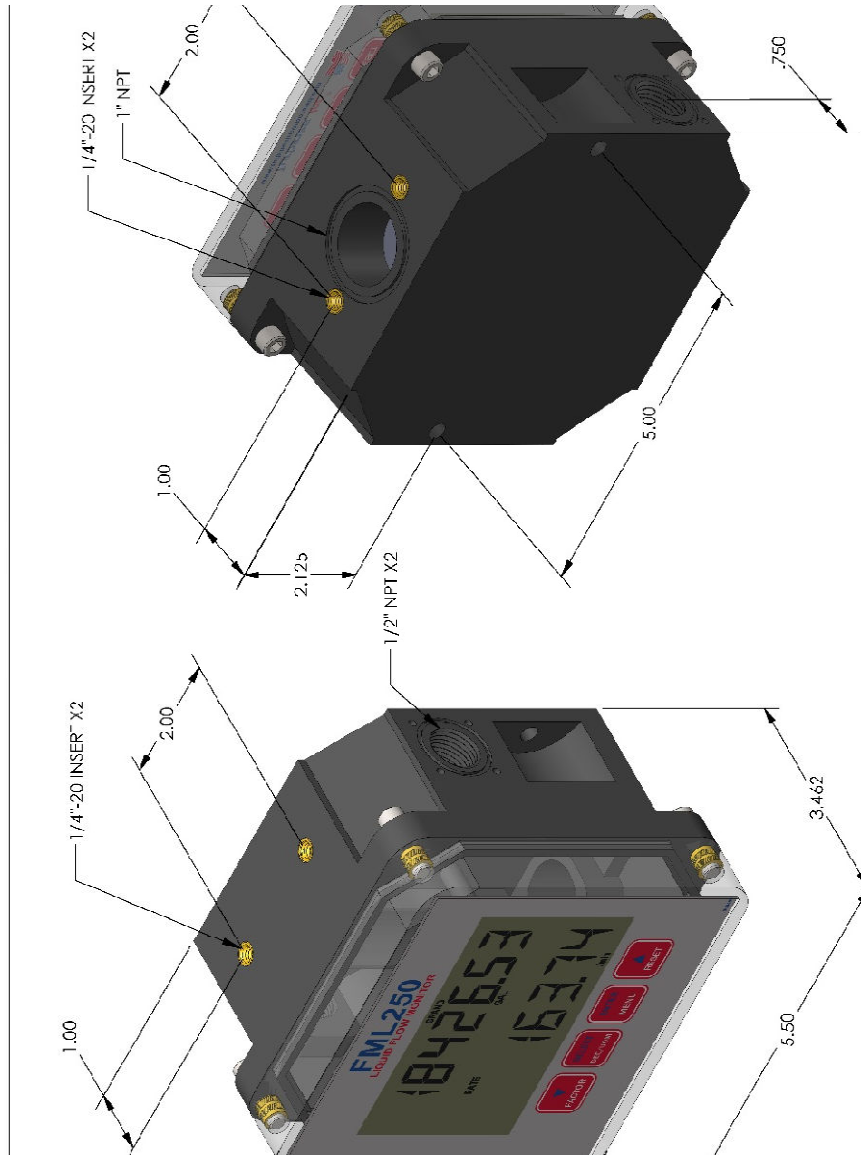

UNIVERSAL		DATE		4-22-13	
FLOW METER		NAME		EDWARD HUEY	
TITLE		DRAWN			
FML250		CHECKED			
SCALE: 1:1		ENG APPR			
WEIGHT:		SEE DWG NO.		A	
SCALE: 1:1		SCALE: 1:1		A	
DO NOT SCALE DRAWING		DIMENSIONS ARE IN INCHES		TOLERANCES UNLESS SPECIFIED:	
		FRACTIONAL 1/64"		DECIMAL ±0.01	
		TWO PLACE DECIMAL		THREE PLACE DECIMAL ±0.005	
		MATERIAL			
		FINISH			
		ECN		APPROVAL	
		PROPRIETARY AND CONFIDENTIAL		THE INFORMATION CONTAINED IN THIS DRAWING IS THE SOLE PROPERTY OF L. RAINES & D. L.L.C. ANY REPRODUCTION IN PART OR AS A WHOLE WITHOUT THE WRITTEN PERMISSION OF L. RAINES & D. L.L.C. IS PROHIBITED.	



Wiring

All of the FML250 connections are made through one removable connector. To access the connector, remove the face cover of the unit and observe connector (TB1) on the back of the main circuit board.

Wiring Guidelines

Universal Flow Monitors, Inc. recommends the following practices be followed:

- All wires connected to the unit should be shielded
- To help avoid ground loops and unexpected behavior, it is recommended that the opposite end of any cable shield is left unconnected (the end opposite the FML250)
- Care should be taken to ensure no part of any wire is not fully inserted into a connector to avoid shorting other circuitry on the mounting board
- Shields should not cover more than one set of signal wires at a time
- Supply wires should be 28AWG minimum

Maintenance and Service

The only user serviceable parts of the FML250 aside from the TB1 and TB2 connectors are the batteries. The FML250 requires no routine maintenance aside from checking the battery low indicator on the LCD. When indicating a low battery, follow the instruction in the **Batteries and Battery Installation** section. When servicing the battery, take care when opening the cover of the unit that any internal signal or power wires are not strained or pulled.

Enclosure

In order to maintain enclosure ratings the following torque specs must be followed:

Item	Torque
All four cap bolts	14 in-lbs
½" NPT fittings	Finger tight + 3 turns
1" NPT fitting	Finger tight + 2.5 turns



Batteries and Battery Installation

The FML250 comes standard with one 3.6 Volt Primary Lithium cell. This battery (as supplied standard) acts as the primary power for the unit unless DC power or loop power is connected when it then serves as a battery backup for DC/loop power loss. When the LCD indicates the battery needs to be replaced, follow these steps to ensure no information is lost during the replacement:

1. Press the Menu button – This will save important run data
2. Remove the four cap bolts securing the cover
3. Remove the clear cover
4. Disconnect the battery cable from the connector behind the overlay by depressing the locking mechanism integrated into the cable connector
5. Loosen the battery strap (#1 Philips head cap screw at the slotted end of the battery strap)
6. Swing the battery strap away from the battery freeing the battery
7. Remove the old battery
8. Install a new battery in the cradle in the back portion of the enclosure (the wire may face up or down)
9. Reconnect the battery connector into J1 ensuring the locking mechanism is facing to the left (toward the edge of the board closest the connector).
10. Reassemble the unit in the reverse order
11. The unit is now ready for use

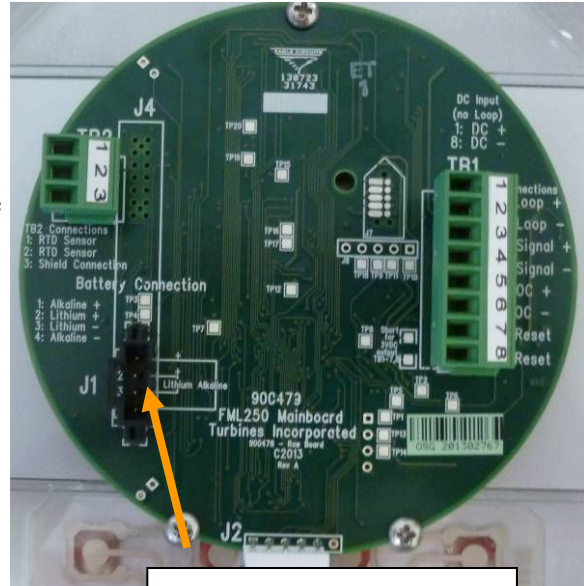

J1 Battery Connector

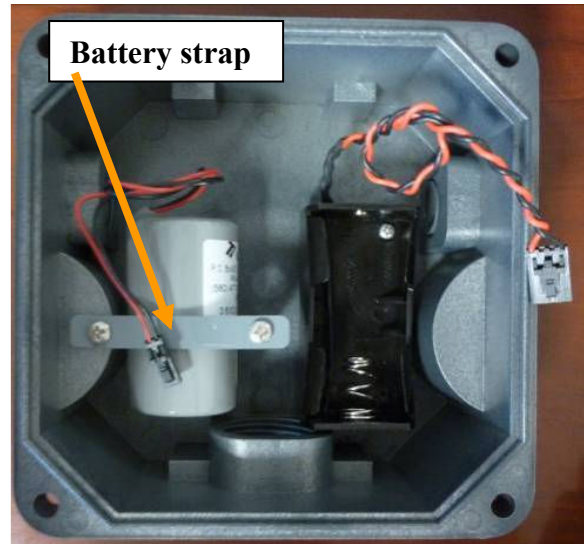

Lithium Battery Pack (TI P/N: 900252):

Life: Around 5 years (power mode 3 at 500Hz continuous use)

Connector: 2-pin (Positive pin 2, Negative pin 3)

Voltage: 2.9 to 3.7VDC

Compliance: Must be UL Listed

Note: Never connect a Lithium battery pack to a four pin connector (and then to J1). This will cause severe damage to the FML250. Only ever connect a Lithium battery pack that is approved by UFM for use on the FML250 and to pins 2 and 3 of J1.

Only accessories which meet UFM specifications shall be used.

Connections

The connections are listed on the rear of the FMG250 board. For clarification, the connections are:

TB1 (For Loop Powered Operation)	
1	Loop DC Positive
2	Loop DC Negative
3	Flowmeter Signal Positive
4	Flowmeter Signal Negative (and shield)
5	OC Pulse Output Positive
6	OC Pulse Output Negative
7	External Reset (+)
8	External Reset (-)

For units with a 'T' in the model number:

TB2 – Temperature Probe Input (optional)	
1	RTD
2	RTD
3	Probe Shield

When connecting external power and not using the loop output, use the following connections:

TB1 (For DC Powered Operation)	
1	DC Positive
2	N/C
3	Turbine Signal Positive
4	Turbine Signal Negative (and shield)
5	OC Pulse Output Positive
6	OC Pulse Output Negative
7	External Reset (+)
8	DC Negative/External Reset (-)

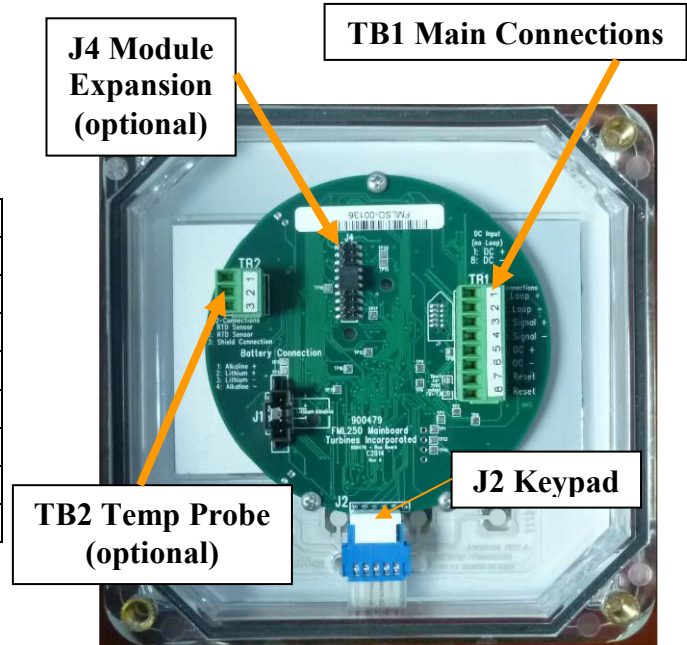

FML250 wiring

The FML250 supports connections with a variety of external devices: DC power supply, 4-20mA Current Loop receiver, Turbine sensor, Pulse Counter, Temperature probe and Reset Switch. A block diagram illustrating the FML250 connection to the external devices is presented below.

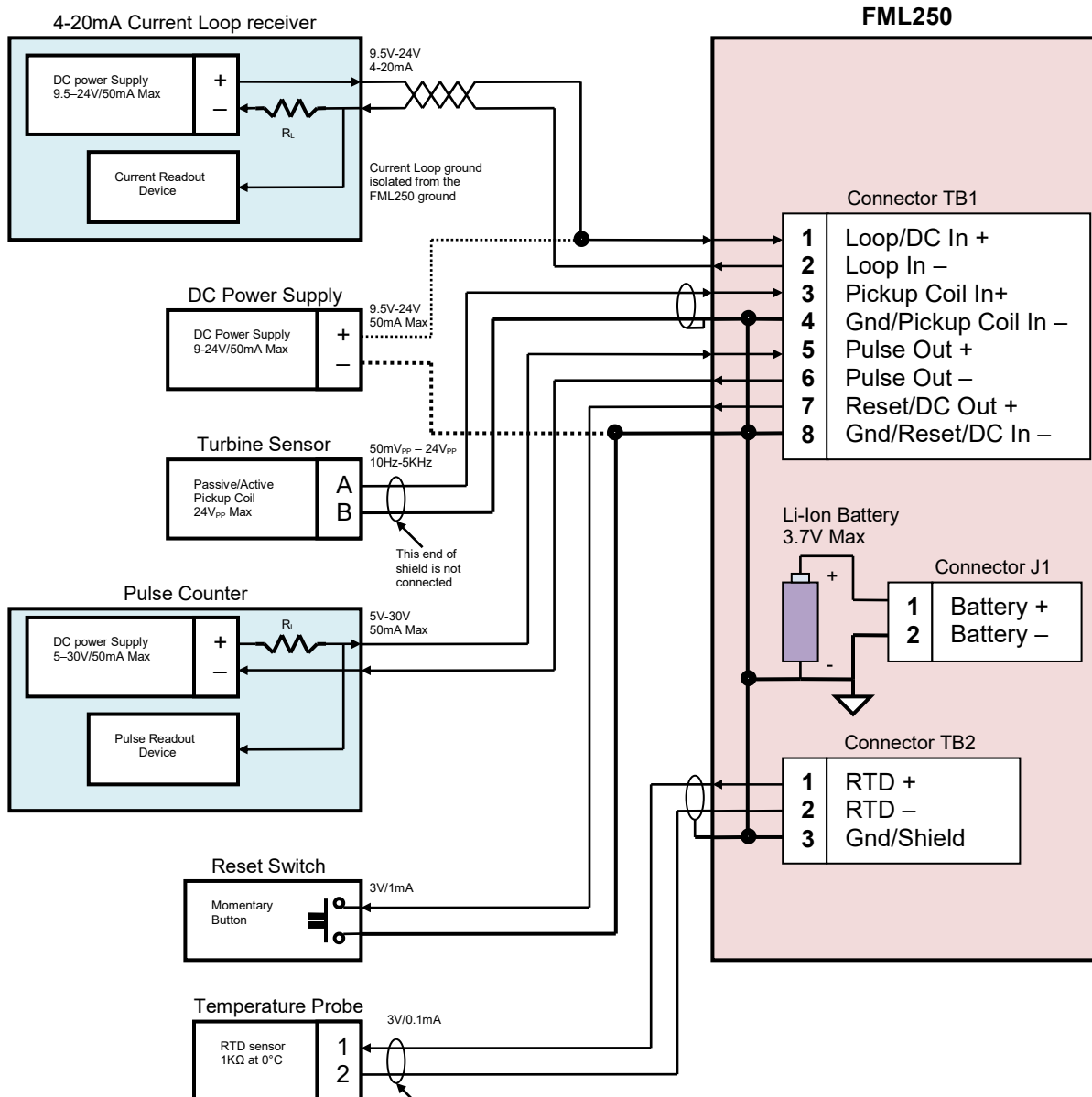

Wiring the FML250 with T Adapter board

The FML250 including the HART Adapter board supports, in addition to the FML250 external devices, the communication with a Highway Addressable Remote Transducer (HART) compliant device. A block diagram illustrating its connection with the external devices, including a HART Transceiver is presented below.

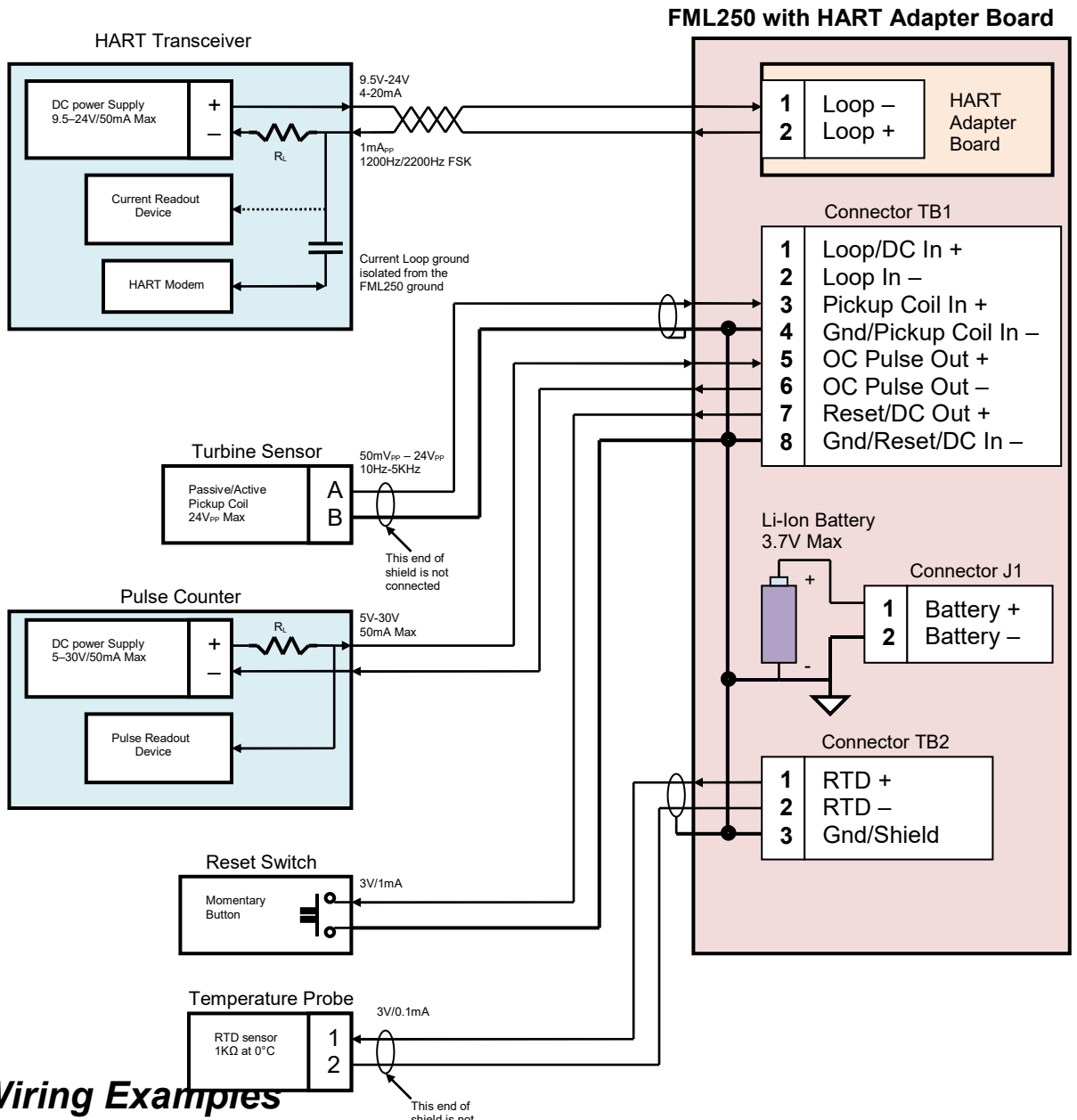

Wiring Examples

Wiring diagrams showing the specific connection of each external device with both FML250 versions are presented below.

External DC Power Supply

FML250 can be supplied from an external DC power supply capable to deliver 9.5V to 24V and a maximum current of 50mA. The internal Li-Ion battery provides in this case a supply backup for assuring an uninterrupted operation of the FML250 in the eventuality that the external DC supply fails.



Notes:

When supplying the FML250 from an external DC power supply the 4-20mA Current Loop is not used.

External power to be supplied by a Class 2 or Limited Energy Source in accordance with CSA 61010-1-12

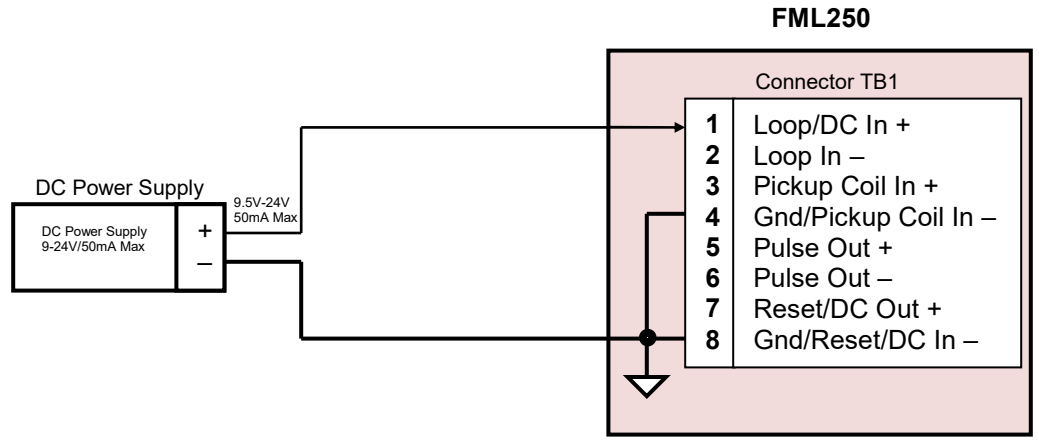

External DC power supply wiring.

4-20mA Current Loop Receiver

The 4-20mA current loop provides an output current proportional with the measured flow rate in the range of 4mA to 20mA. The two main components of the Current Loop receiver illustrated below are a DC power supply and a current readout device. These two components of the Current Loop receiver, although shown together, can also be implemented as two separate units. The R_L resistor also may be included or not in the Current Readout device. The 4-20mA Current Loop receiver is connected to the FML250 through two twisted conductors and its DC power supply delivers to the FML250 a voltage of 9.5V to 24V and a maximum current of 50mA. The internal Li-Ion battery provides in this case a supply backup for assuring an uninterrupted operation of the FML250 in the eventuality that the DC power supplying the Current Loop fails.

Notes:

In order to assure the Current Loop proper operation The Current Loop receiver ground has to be insulated/floating with regards to the FML250 ground.

Current Loop power to be supplied by a Class 2 or Limited Energy Source in accordance with CSA 61010-1-12



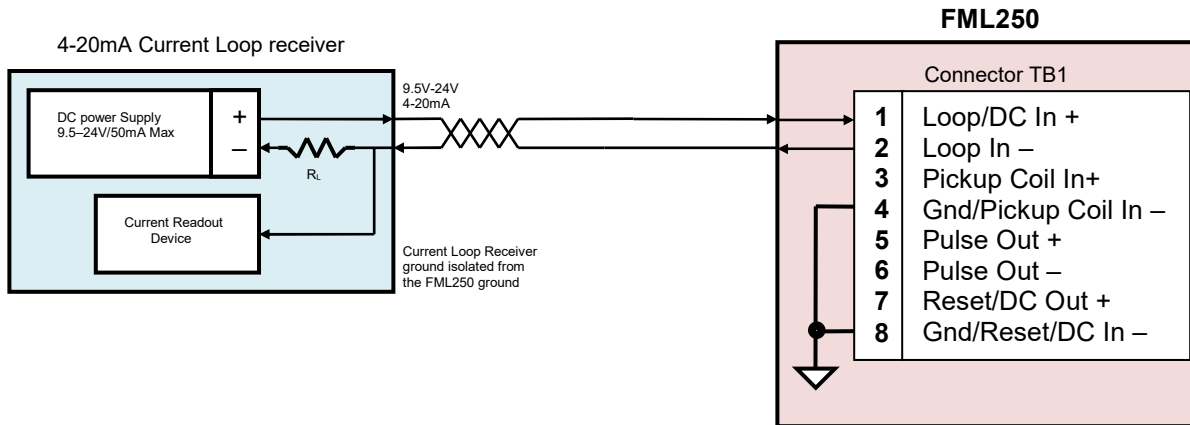

4-20mA Current Loop output wiring.

Turbine Sensor

The turbine sensor provides the FML250 with a signal generated by a passive or active magnetic pickup coil.

The signals generated by the passive magnetic pickup coil are sinusoidal in shape and have amplitude in the range of $50mV_{PP} - 24V_{PP}$ and the frequency in the range of $10Hz - 5 KHz$ while the active magnetic pickup coil delivers pulses with $3.6V - 15V$ amplitude in the same frequency range.

The active magnetic pickup coil is powered from an external DC power supply with a voltage of $4.3V - 24V$ or, optionally, by the FML250 itself with a voltage of $4.3V$ and a maximum $1mA$ current.

The various configurations for connecting the turbine sensor to the FML250 are illustrated below.

Notes:

For IS version of the FML250 a IS certified magnetic pickup coil has to be employed.

Active magnetic pickup coil power has to be supplied by a Class 2 or Limited Energy Source in accordance with CSA 61010-1-12

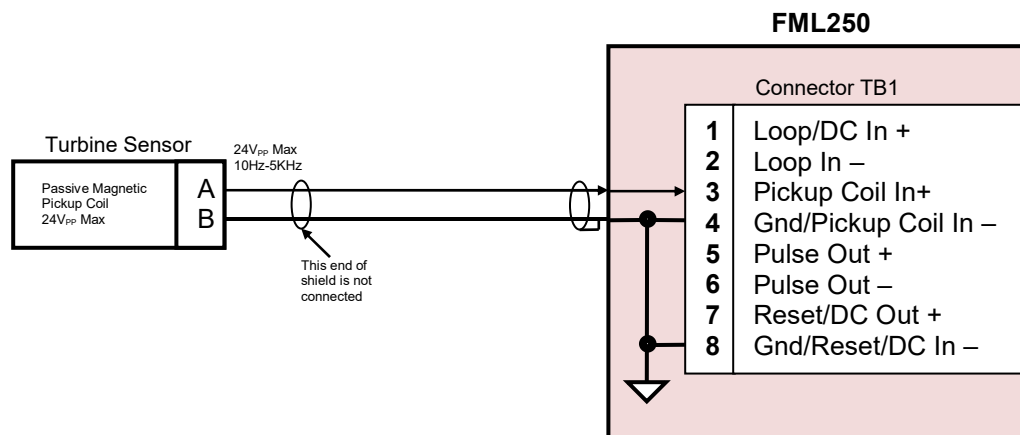

Passive magnetic pickup coil output wiring

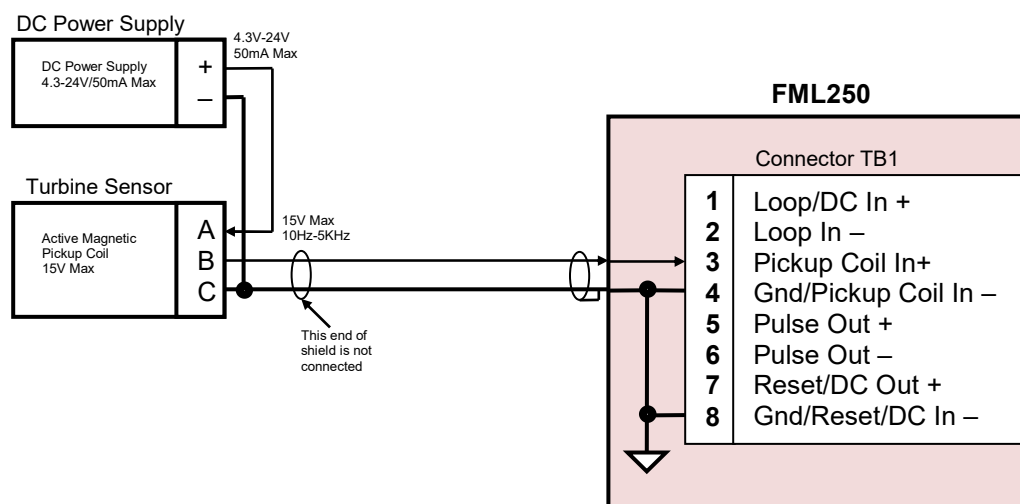

Wiring of an active magnetic pickup coil supplied by an external DC power supply.

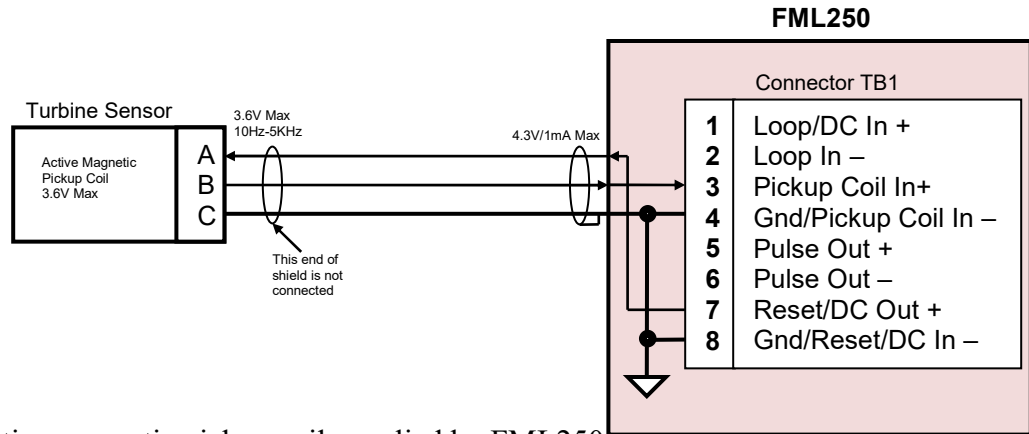

Wiring of an active magnetic pickup coil supplied by FML250.

Pulse Counter

The pulse counter, formed by a DC power supply and a pulse readout device, detects and accumulates the factored pulses received from the FML250 pulse output. The rate of factored pulses created by FML250 is based on the flow rate information received from the turbine sensor and a user-defined volume per pulse ratio. The pulses produced by the FML250 are sent to the pulse output through an optocoupler which assures 5KVrms ground isolation. The pulse output acts as a unidirectional solid-state relay and has a maximum rating of 30V and 50mA. Due to the isolation provided by the optocoupler the pulse output acts as an open collector that can be configured with the R_L as a pull up or pull down resistor, as it is illustrated in the below wiring diagrams.

Although the DC power supply and pulse readout device are shown as part of the pulse counter, they also can also be implemented as two separate units with the resistor R_L included or not in the pulse readout device.

The two configurations for connecting the pulse counter to the FML250 are illustrated below.

Note:

Pulse counter DC power to be supplied by a Class 2 or Limited Energy Source in accordance with CSA 61010-1-12

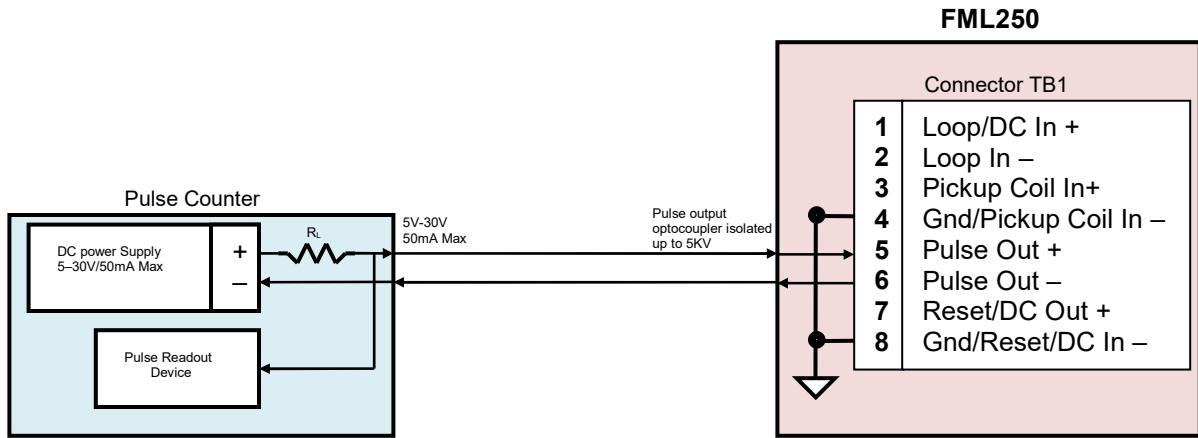

Pulse counter wiring for an open collector, pull up R_L configuration.

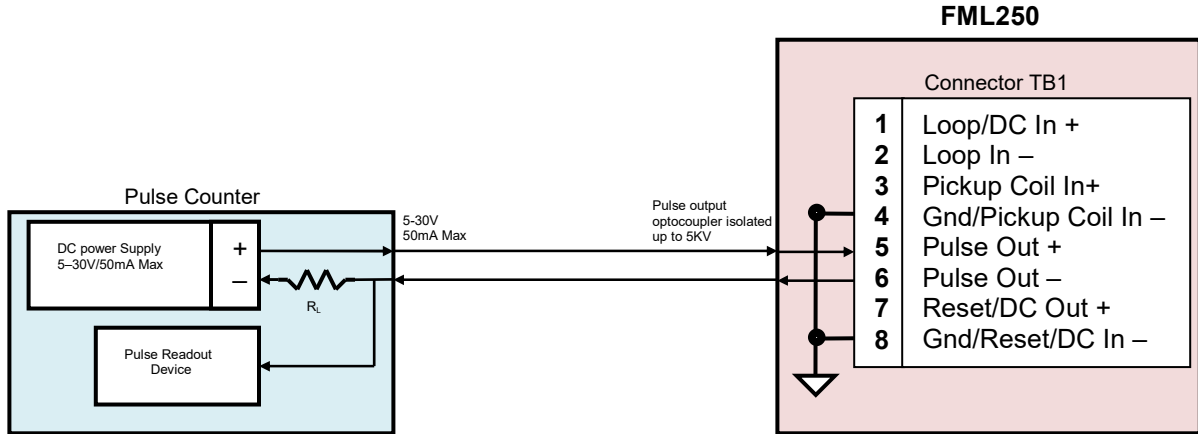

Pulse counter wiring for an open collector, pull down R_L configuration.

Temperature Probe

Temperature probe uses a Pt 1000 RTD as a temperature sensor. The FML250 supplies the RTD sensor with a 0.1mA current which produces across the RTD a voltage proportional to the temperature at which it is exposed. The voltage is sent to RTD input and further used for temperature compensation, allowing the FML250 to provide accurate flow rate data. The temperature probe wiring is shown below.

Note:

For IS version of the FML250 the temperature probe is considered a simple apparatus as defined in the IEC 60079-11 standard.

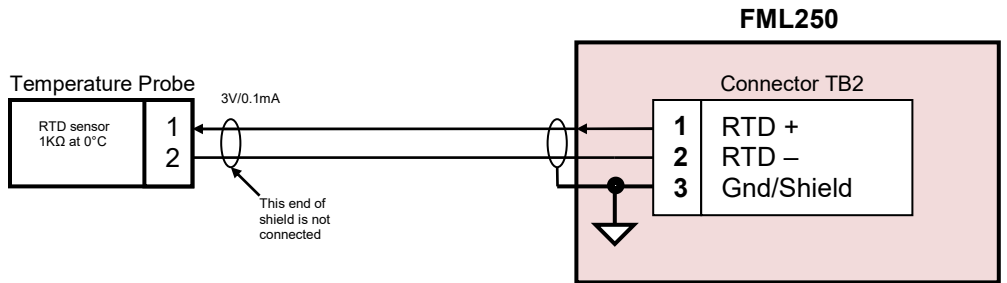

Temperature probe wiring.

Reset Switch

The reset switch role is to reset the FML250 total volume to zero without requiring access to the interior of its enclosure and this is accomplished by remotely short circuiting the reset input to ground.

The reset switch wiring is shown below.

Note:

For IS version of the FML250 the reset switch is considered a simple apparatus as defined in the IEC 60079-11 standard.

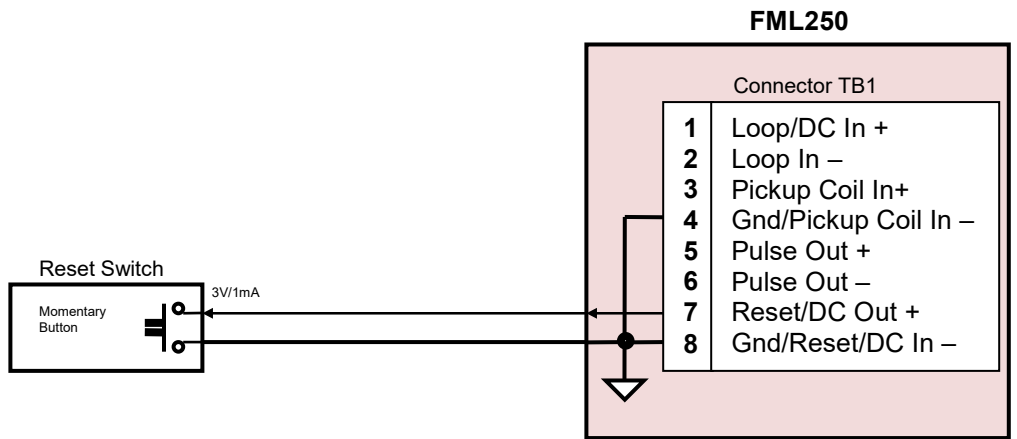

Reset switch wiring.

HART Transceiver

The HART adapter board provides the FML250 with an alternate way for communicating with an HART compliant. The HART communication is a half duplex 1200 bps serial data link implemented by superimposing an AC neutral FSK modulated signal over a 4-20mA loop current. The 4-20mA analog signal is used to communicate the primary measured value, the flow rate, while the superimposed FSK signal allows additional information exchange with FML250, including its status, additional measured values, etc.

The HART transceiver wiring is shown below.

Notes:

In order to assure the Current Loop proper operation The Current Loop receiver ground has to be insulated/floating with regards to the FML250 ground.

Current Loop power to be supplied by a Class 2 or Limited Energy Source in accordance with CSA 61010-1-12

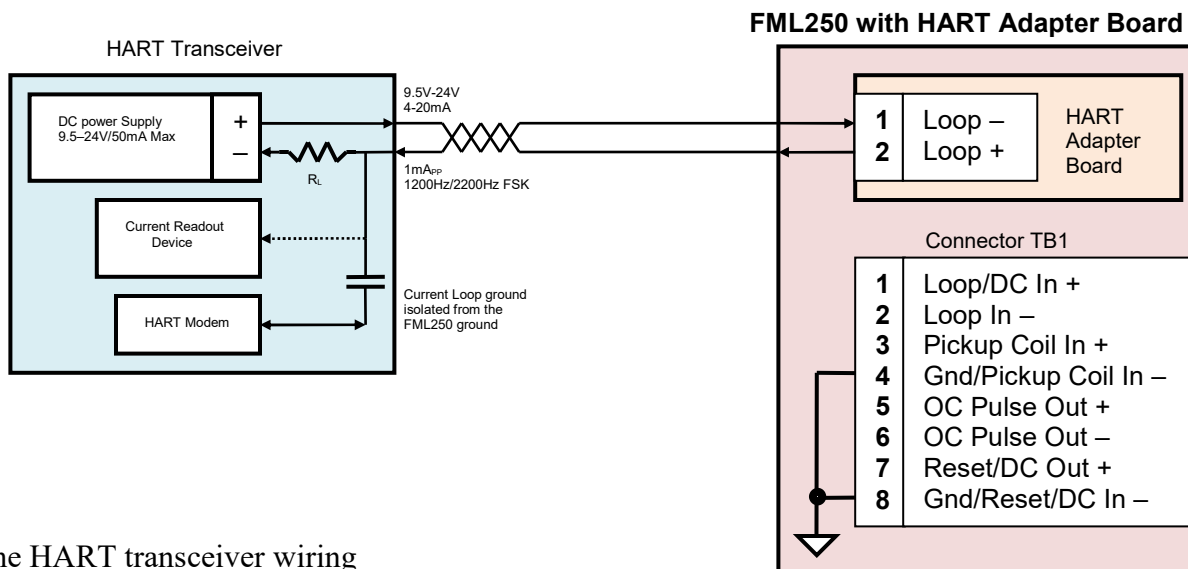

The HART transceiver wiring

Caution:

For an IS certified FML250 installed in a hazardous location, all field wiring must conform to wiring methods for explosion-proof installations as defined by the National Electric Code in United States or by the Canadian Electric Code in Canada. Other International, State and local wiring codes may also apply.

Operation Overview

Details of the operation of the FML250 can be found in this section.

Flow Calculations

Calculation for uncompensated flow rate:

$$FlowRate = \frac{Fin}{KFactor}$$

Calculation for uncompensated flow total:

$$FlowTotal = \frac{PulseInSum}{KFactor}$$

Grand total is calculated independently from total.

Linearization

Linearization, as it pertains to the FML250, is the selection and interpolation of a K-Factor from a table of calibrated values based on frequency. Whenever a new frequency is detected, the unit will look up adjacent frequency values in the linearizer table and calculate a K-Factor (using linear interpolation). If the frequency value is below the lowest frequency in the table, then the linearizer uses the lowest point in the table. If the frequency value is above the highest point in the table, then the linearizer continues to use the K-Factor from the highest point in the table.

Temperature Compensation (optional)

The FML250 can optionally calculate the expansion and contraction of liquids based on the temperature of a given fluid. This calculation is based on a known expansion coefficient and the difference in the current temperature and the one referenced by the expansion coefficient. This "T/C factor is then applied to the current K-Factor (determined either from the straight K-factor or calculated from the linearization table) prior to calculation of the Totalizer and Ratemeter values. The calculation for adjusted volume is most accurate at the reference temperature and decreases as the actual temperature deviates from the reference. Option "TC" must be ordered when the unit is purchased. Use of temperature compensation will reduce the life of the battery.

U/M

All unit of measure calculations are based on the conversion of the desired unit of measure to the system units of measure (Gallons or Liters). Special units of measure are available for weight equivalent units such as pounds and kilograms. These conversions are straight conversion from gallons (or l) to weight based on the weight of one gallon (or l) as entered in the menu for that UOM.

Pulse Output

The pulse output of the FML250 consists of an optically isolated open collector pulse output, a pulse width, and a pulse divider. To calculate the pulse output, the unit takes the net grand



totalizer value for the last update time and divides it by the pulse output divider (in the setup menu). Because the divider is allowed to be smaller than 1, the pulse divider can be made to be a multiplier. Here is the formula that is used:

$$OutputPulses = \frac{LastUpdateTotalizerPulses}{PulseOutDivider}$$

The pulse width is the number of milliseconds the pulse is active. This will need to be small enough that all of the pulses that need to be outputted have time to complete, but large enough that the receiving equipment can still detect them. To calculate the maximum pulse width:

$$PW_{max} = \frac{PulseOutDivider}{(TotalOutputPulses / Second * 2)}$$

Note: Pulse Width is ½ of Pulse Period.

Example: If the totalizer is observed to be increasing by 300 every second and the Pulse Output Divider is set to 10, then the maximum allowed pulse width is:

$$PW_{max} = \frac{10}{300 * 2} = 0.0166s = 16ms$$

Note: The output pulse is indicating that one (totalizer U/M) / (Pulse Output divider) has flowed through the meter.

Note: If the display shows “E” on the top left digit, then the pulse output system is being overloaded and output pulses are being lost. This is due to the above calculation being exceeded (the pulse width is too wide for the number of pulses being asked to be outputted per second). This can be solved in several ways: Reduce the Pulse Width, Reduce the number of decimal places in the Totalizer, or increase the Pulse Divider.

Warnings

The FML250 has an extensive warning system that serves more than to alert the user to operation outside a set of parameters. As can be seen in the menu system section of the manual, there are several parameters within the system that are continuously monitored. Most of these warnings do not affect the operation of the unit. For example, if the rate is out of range, the total and grand total calculations are still performed as they are described above. In these cases, the only indication of a warning is the warning icon (see the Front Panel Display section) and if the warning value is displayed (such as rate), then instead of the actual number, the display will indicate the warning. The warning will show as “--L--” (over limit), “--LL--” (under limit), etc.

Alarms

When action is needed when a warning is active, the FML250 has an alarm system. This alarm system takes the warning system and puts it into action. As can be seen in the Alarm menu item, any given warning can be made to activate the alarm system. The alarm system is only active during the actual time that the selected warning is also active. It can be noted that the alarm values

for a given alarm are identical to the corresponding warning value. One can think of the alarm system to be the logical AND of the warnings and the selected Alarms. Because of this, only the desired warnings will trigger the Alarm system.

The only alarm system action is the “No Total” which is used to stop the totalizers from counting. For instance, if the Low Rate warning value is set to 5 (U/M is always the same as the displayed U/M), the Low Rate Alarm is set, the No Total Alarm is set, and the flow input calculated value is below 5, then the totalizer will not accumulate even if there are pulses coming in on the flow input. In this way, any enabled Alarm that has a corresponding active warning will cause the totalizer to stop.

There are a few warnings that cannot be made to trigger the Alarm system. These can be noted in the Warnings section of the Test menu.

Display

The display consists of two numeric blocks: the Upper value and the Lower value. Both of these blocks display a value from a list of available values set in the menu system. The Upper value is sequenced by swiping pressing the **SELECT** button. The Lower value is sequenced automatically using a timer. The value of the timer is set in the Display menu. Each display can be made to display only one value by setting all of the other slots to “Skip”. Any display slot may be set to Skip.

Reset

The FML250 has two totalizers. The total that is indicated with **TOTAL** is resettable. The total that is indicated with **GRAND** is not resettable. There are three means by which the resettable totalizer can be reset:

- The **RESET** button on the front panel can be pressed while in run mode. The lower display indicates “--RESET--”.
- The reset input pins (TB1-7 and TB1-8) can be shorted for a brief time. The pulse must be at least 50ms. The lower display indicates “--RESET--”
- The reset menu item can be activated.

Power

The FML250 can receive power from four sources:

- An internal Lithium battery pack
- External 4-20 mA loop source
- External VDC source

When the unit is powered from TB1, the battery will act as a backup supply of power if/when the external power is lost. This switch over is instantaneous and automatic. No user intervention is needed. The unit will only use the battery if the voltage on TB1 is below the input voltage specification.

When running on battery, power can be conserved by adjusting the refresh rate of the unit by changing the power mode. When observing the power mode menu item, the number of times the

unit will refresh is shown on the right. By causing the unit to refresh less often, less power is used to recalculate and display any updated values. This can also be used to “slow down” or filter the display to make it less jumpy. Values will effectively be averaged over the time between refreshes.

Power Mode	Refresh Rate (#/s)
0	0.5 (one update every two seconds)
1	1
2	2
3	4
4	8
5	16
6	Continuous*

* In continuous mode, the refresh rate is not tied to any timer and will occur as fast as the internal calculations will allow.

Auto-Calibration

The FML250 has an Auto-Calibration feature that allows the user to easily adjust the K-factor based on a known delivery of liquid. The feature takes a displayed value of product that is observed on the FML250 display and automatically calculates an adjusted K-factor based on the actual value of that delivery.

Additionally, a prove is available for performing the displayed delivery portion of the Auto-Calibration mode on the fly. Delivery total will be displayed during the prove run. Any total added during the prove run will be added to the main totalizer as well as the grand totalizer.

Given:

- T(displ)* – Total Displayed in configured units of measure (Entered by the user or automatically calculated by current K and received pulses from the turbine during prove mode)*
- T(act)* – Actual Total Delivered in configured units of measure entered by user
- K(cur)* – Current K-factor (in PPG or PPL)

Percent error:

$$Error(\%) = \left(\frac{T(displ) - T(act)}{T(act)} \right) * 100$$

Calculated (new) K-factor:

$$K(calc) = \left(\frac{Error(\%)}{100} * K(cur) \right) + K(cur)$$

*For temperature compensated units, if Compensation is enabled for normal operation, it will be used when accumulating the above totalizer value *T(displ)*.



Front Panel Display and Controls

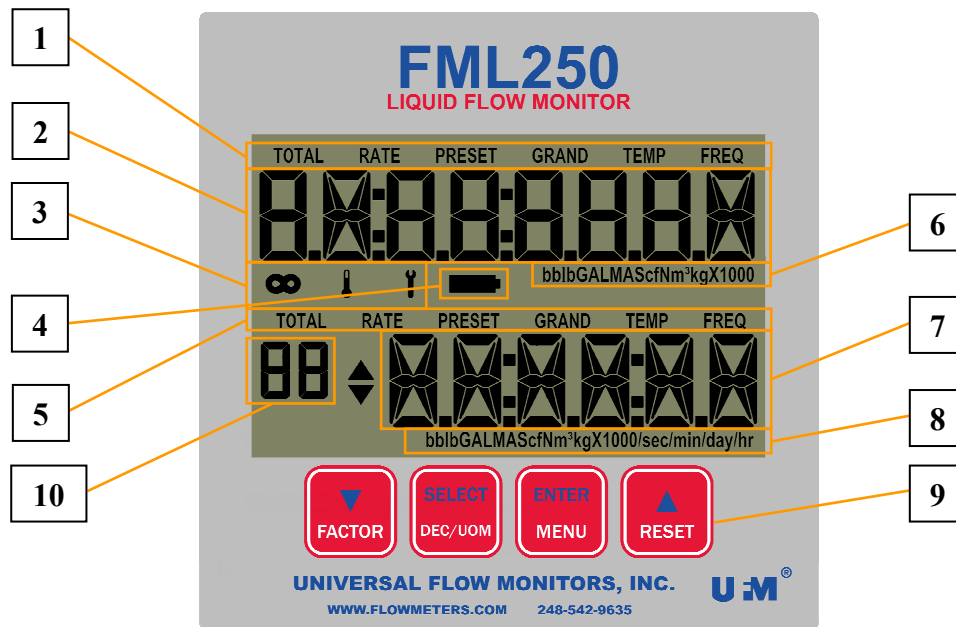

1. **Upper display type indicator** – This portion of the display indicates what value is being displayed in the upper display value.
2. **Upper display value** – This is the upper display value. This is one of the items in the upper display list and is selected with item #1 above.
3. **Warnings/errors indicator** – These icons indicate one or more of the following items are outside the warning limits:
 - a. **Infinity** – Flowrate
 - b. **Thermometer** – with optional Temperature compensation: Flashes on to indicate a temperature sample has occurred. If this is on most of the time, then the temperature sensor has a hardware fault (short or open).
 - c. **Wrench** – Maintenance timer has expired. In addition, there are several other fault and warning conditions that may cause this icon to illuminate. See the Warnings section in the Operation Overview below.
4. **Battery** – The battery icon indicates the battery is below normal operating voltage and must be changed.
5. **Lower display type indicator** – This portion of the display indicates what value is being displayed in the lower display value.
6. **Upper display units of measure** – These will show the units of measure for the upper display (usually Total/Grand Total). On some units, these icons show the combined units of measure for the unit (The lower display UOM icons are not present). Note: this is only used for flow values (not temperature, etc.).

7. **Lower display value** – This is the lower display value. This is one of the items in the lower display list and is sequenced via the lower display timer.
8. **Lower display units of measure** – These will show the units of measure for the lower display (usually Rate). Some units only show the time base for the lower display.
9. **Front panel buttons** – These buttons are used together to manipulate all of the items, values, and selections in the menu system.
 - a. **▼/FACTOR:**
 - i. **Run:**
 1. **Holding** – Holding the factor button down at any time in run mode will change the upper display to the current K-factor the unit is using for calculations (in pulses/Gallon or pulses/Liter). A linearized value is indicated by the presence of an ‘L’ after the number. In this case, the number listed is the numerically linearized factor calculated from the linearizer table.
 2. **Quickly Pressing** – Quickly pressing the factor button will cause the menu to be entered and quickly jumped to the factor editing menu (or meter size if easy menu is selected prior).
 - ii. **Menu** – Sequences through menu items or selections (in reverse).
 - b. **SELECT/DEC/UOM:**
 - i. **Run**– Sequences the upper display through its display list. If a value is in error, then holding the button will display the default value (that is, the value being used for calculation purposes).
 - ii. **Menu** – Is used to select menus for entering or editing.
 - c. **ENTER/MENU:** Enters the menu system, accepts changes, and exits menu items within the menu system.
 - d. **▲/RESET:**
 - i. **Run** – Causes the resettable totalizer to become zero.
 - ii. **Menu** – Sequences through menu items or selections.
10. **Menu/Submenu item number** – Shows the Menu or Submenu number that is currently being viewed or edited. This will correspond to the number listed in the Menu System and the Main Menu Flowchart sections of this manual.

Menu System

The Menu system consists of several items that allow the user to manipulate aspects of the FML250's operation. The menu can be entered two ways:

1. Pressing the **MENU** button – When entering the menu using the **MENU** button, the user is presented with the option of three menu types:
 - a. EASY (EASY) – This menu only asks for the following items:
 - i. Meter Size – This is the size of the meter and will automatically use the standard factor for Universal Flow Monitors, Inc. standard FM Series flowmeters.
 - ii. Unit of measure
 - iii. Time Unit of measure
 - b. FACTOR (FACTOR) – This sequences through all of the menu items below except for the Linearizer section.
 - c. LINEAR (LINEAR) – This sequences through all of the menu items below except for the Factor section.
2. Pressing (momentarily) the **FACTOR** button
 - a. This enters the menu system starting with the following based on previous selection:
 - i. EASY: Meter Size
 - ii. FACTOR: K-Factor
 - iii. LINEAR: Linearizer

User Interface

All values and selections within the menu system are manipulated through the use of the front panel buttons. These four buttons have overloaded functions that allow a simple yet effective means of entering data. To enter the menu system, press the **ENTER/MENU** button.

Navigating the menu:

- **▲/RESET**
 - Step forward through the various menu, submenu items, and selections
- **ENTER/MENU**
 - Initially used to enter the menu system
 - Once a value has been changed, this button is used to accept the new value/selection. If a new value/selection is presented and this is not pressed, then the changed value will be ignored
 - If a value has not been changed, this is used to exit the menu or drop out of a submenu
- **SELECT/DEC/UOM**
 - Used to allow a new selection of the displayed menu item to be made using the arrow buttons (▲/▼) (the wrench icon will flash when the arrows are active)

- Used to enter a submenu (such as the Test submenu).
- When the battery icon is displayed for a custom/editable value, holding this will allow editing of the custom value.
- **▼/FACTOR**
 - Step backward through the various menu, submenu items, and selections

Editing a number:

Some numbers in the menu can be edited. This is denoted by the existence of the batt icon on the display. When this is present, the **SELECT** button can be held to gain access to edit the number.

- **▲/RESET**
 - Used to step forward through the current item selections
 - Used to increment the value of the selected digit or the decimal point (when flashing)
- **ENTER/MENU**
 - Used to accept the currently displayed portion of the value and move on to the next portion of the edit (up to three portions: sign, significand, and decimal)
- **SELECT/DEC/UOM**
 - Any time the batt icon appears in the menu, this button can be used to begin the editing steps (hold to edit)
 - Once editing has started, this button toggles the sign (if available) and steps through the digits to be changed
- **▼/FACTOR**
 - Used to step backward through the current item selections
 - Used to decrement the value of the selected digit or the decimal point (when flashing)

Menu System Items

To enter the menu system, press the **ENTER/MENU** button from run mode. A Lockout code may be required. If so, enter the lockout code by using the encoders as described above (Editing a number).

Note: The K-factor may be easily directly accessed by pressing the **FACTOR** button from run mode based on previous selection:

- EASY: Jump to the Meter Model Number section below (#4)
- FACTOR: Jump to the K-Factor section below (#2)
- LINEAR: Jump to the Linearizer section below (#3)

1. Menu Selection

Selects between the EASy setup, single K-Factor, and Linearizer operation

1.1. EASy setup (EASy)

This selection will allow a very quick and easy subset of the parameters needed to setup the FML250 for use with a standard Universal Flow Monitors, Inc. turbine flow meter. If this item is selected, only the following will be available in the menu:

- Meter Size (#4): This is the UFM, Inc. meter part number
- Totalizer U/M (#5)
- Rate U/M (#7)
- Time U/M (#9)

Other menu item assumptions are (made when the meter size is selected)

- Totalizer Decimal: 0.1
- Rate Decimal: Autorange
- 4-20mA: Low and high values are set to the range of the flow meter selected
- Warning (Flow): Low and high values are set to the range of the meter selected
- Pulse Output is disabled
- All other settings are left unchanged

2. K-factor (KFACTOR)

When K-Factor selection is made, this item allows the editing of the K-Factor. The unit of measure is fixed to the UOM System selected in the Service menu.

3. Linearizer (LINEAR)

When Linearizer selection is made, this item shows the number of valid linearizer points that are currently entered. Pressing the **SELECT** button will allow the linearizer table to be edited. Once pressed, the linearizer table can be stepped through using the ▲▼ buttons. To edit a number, press the **SELECT** button again. A frequency value of zero will indicate no more points are to be entered. To save the linearizer table, after editing any number, press the **MENU** button. If the table is acceptable, it will be saved. Note: The points must be entered in ascending frequency order and contain at least two points.

4. Meter Model Number (METER)

When the EASy menu is selected, the K-factor is selected by selecting the meter size. This configuration is meant to be used with UFM, Inc. standard turbine flow meters which part numbers start with "TM".

5. Totalizer Units of Measure (TUM)

Selects which unit of measure is desired for the totalizer in the FML250. Items that show the batt icon are user editable conversions. To edit, hold **SELECT**. Once done editing, be sure to press



MENU to accept the custom selection as the active conversion. The custom unit (the one that has no unit icon) is based on Gallons. This conversion is the number of units per Gallon that are desired. The following units of measure *SCF/GAL*, *MSCF/GAL*, *SM3/GAL*, & *MSM3/GAL* are editable and are meant to be used for gas equivalent conversions usually in cryogenic liquid measurements. A table of common gas equivalents can be found in the appendix.

6. Totalizer Decimal place (E dEE)

The fixed decimal location to be used for the totalizer and the grand totalizer functions.

7. Ratemeter Units of Measure (R UNI E)

Selects which unit of measure is desired for the ratemeter of the FML250. Items that show the batt icon are user editable conversions. To edit, hold **SELECT**. Once done editing, be sure to press **MENU** to accept the custom selection as the active conversion. The custom unit (the one that has no unit icon) is based on Gallons. This conversion is the number of units per Gallon that are desired. The following units of measure *SCF/GAL*, *MSCF/GAL*, *SM3/GAL*, & *MSM3/GAL* are editable and are meant to be used for gas equivalent conversions usually in cryogenic liquid measurements. A table of common gas equivalents can be found in the appendix.

8. Decimal place (R dEE)

The fixed decimal location to be used for the ratemeter functions. The autorange option “--RLEE--” causes the ratemeter decimal place to change automatically.

9. Time U/M (E ME)

Selects the time base for the Ratemeter function. The custom unit (the one that has no unit icon and shows the batt) is based on seconds. So, this conversion is the number of seconds per unit that are desired. To edit, hold **SELECT**. Once done editing, be sure to press **MENU** to accept the custom selection as the active conversion.

10. TEMP UNIT (UNI E) (w/ T/C option only)

Selects which unit of measure is desired for the System Temperature display. To change, press **SELECT**. Selections are:

- F – Fahrenheit
- R – Rankin
- C – Celsius
- K – Kelvin



11. Compensation (COMPEN) (w/ T/C option only)

The Compensation menu allows modification of values that are used by the temperature compensator. Press **SELECT** to enter the pulse input submenu.

11.1. Compensation Enable (COMP)

Enables or disables the temperature compensator as part of the fluid calculations.

11.2. Fluid (FLUID)

Selects the process fluid defaults for the remaining compensation values. If custom compensation values are to be used, this selection can be ignored. The list of pre-programmed liquids can be found in the appendix.

11.3. Default (DEFLE)

The default temperature that is to be used by the compensator when there is a temperature sensor fault (open or short).

11.4. Expansion Coefficient (CO EXP)

This is the expansion coefficient that the compensator uses to calculate the fluid expansion at a certain temperature. This is typically found in published data and is referenced at the Reference Temperature below.

11.5. Reference Temperature (REFRNC)

This is the reference temperature that the Expansion Coefficient is referenced. This is typically found in published data. The UOM for this item is selected by the system temperature UOM above

11.6. Density (DENSITY)

This is the density of the fluid in Pounds per Gallon. This is typically found in published data.

11.7. SCF/GAL (SCFGAL)

This is the expanded gas equivalent of the selected liquid in Standard Cubic Feet per Gallon. This is typically only used in cryogenic liquids.



12. Pulse Input (PUL IN)

The pulse in menu allows modification of values that are used by the pulse input module. Press **SELECT** to enter the pulse input submenu.

12.1. Pulse input type (TYPE)

- **Magnetic(MAGNET):** This is the standard input type for the unpowered pickup coil on most turbine flowmeters. This input reacts to the sensitivity setting.
- **Square(SQUARE):** This input type is for sourced (powered) pulse inputs. These are typically seen in standard powered pickup coils.

12.2. Pulse input sensitivity (SENSE)

Selects the magnetic input pulse sensitivity. A Lower number causes more signal to be needed to trigger a pulse. When Square is selected above, this will only show the current input frequency (no adjustment is allowed in Square input type).

13. Pulse Out (PUL OUT)

The pulse out menu allows modification of values that are used in the pulse output module. The pulse output is calculated based on the value of the grand totalizer over time. As the grand totalizer increases, these pulses are used to determine the output pulses sent to the pulse output. Press **SELECT** to enter the pulse out submenu.

13.1. Pulse Out Enable (OUTPUL)

Selects if the pulse output module is enabled or disabled. When disabled, there is an increase in battery life.

Note: If the display shows “E” on the top left digit in run mode, then the pulse output system is being overloaded and output pulses are being lost. This is due to the calculation described in the Pulse Output section above being exceeded (the pulse width is too wide for the number of pulses being asked to be outputted per second). This can be solved in several ways: Reduce the Pulse Width, Reduce the number of decimal places in the Totalizer, or increase the Pulse Divider.

13.2. Pulse width (PUL WID)

Selects the width of the output pulse in milliseconds. The custom width (the one that shows the batt) is based on milliseconds. To edit, hold **SELECT**. Once done editing, be sure to press **MENU** to accept the custom selection as the active pulse width.

13.3. Pulse Divide (PULSE DIV)

Selects the pulse divider. To determine the number of output pulses, the calculated number of pulses will be divided by this number. Example: The grand totalizer increased by 50 between the last update and the current update. If the pulse divide is 10, then there will be 5 pulses output. If the divider is 1, then 50 pulses will be output. If the divider is 0.1, then 500 pulses will be attempted to be output (in this case, this is effectively a pulse multiplier and should only be used for slow counting pulses). There is a custom divider (the one that shows the batt). To edit, hold **SELECT**. Once done editing, be sure to press **MENU** to accept the custom selection as the active divider.

14. 4-20mA Output (4-20MA)

14.1. 4-20mA Output Enable (OUTPULS)

Enables or disables the 4-20mA output. When disabled, there is a small increase in battery life.

14.2. Low (4mA) Output Set Point (LOW)

Selects the rate value to represent 4 mA output current. The UOM is the same as is set for the Ratemeter.

14.3. High (20mA) Output Set Point (HIGH)

Selects the rate value to represent 20 mA output current. The UOM is the same as is set for the Ratemeter.

15. Warnings (WARNINGS)

The warnings menu allows modification of values that are used to determine the activation of a warning. Warning limits do not affect operation except for display purposes. To cause a warning to affect operation (totalizer inhibit), set the values in this menu and then activate them in the Alarms menu. Press **SELECT** to enter the warnings submenu.

15.1. Rate Low (RATE LOW)

This sets the low Ratemeter warning value. U/M is selected when selecting Rate U/M above.

15.2. Rate High (RATE HIGH)

This sets the high Ratemeter warning value. U/M is selected when selecting Rate U/M above.



15.3. Temperature Low (**TEMP LOW**) (w/ T/C option only)

This sets the low Temperature warning value. U/M is selected when selecting Temperature U/M above.

15.4. Rate High (**TEMP HIGH**) (w/ T/C option only)

This sets the high Temperature warning value. U/M is selected when selecting Temperature U/M above.

15.5. Sample Time (**TIME /SEC**) (w/ T/C option only)

This sets the analog sample time. This is the number of seconds between analog samples. The minimum is 1 to 999 seconds. Press **SELECT** to edit. Setting this timer higher will make the battery last longer but may cause changes in temperature to be skipped.

16. Alarms (**FLARM**)

The alarms menu allows each warning in the unit to trigger cause the totalizer to be stopped (inhibited). The alarm is a “follow” function meaning it is only active as long as there is an active corresponding warning. Press **SELECT** to enter the Alarms submenu. There are several system warnings that can be made to trigger the system alarm:

- 16.1. **No total (0x00001) (NO TOL)** – When this is enabled, the totalizer will be inhibited when any selected alarm and corresponding warning is active. This is useful for preventing the totalizer count when some conditions are unfavorable for accurate flow. For instance, if the flowmeter becomes non-linear below a certain flow rate, then this can be enabled and the low flow alarm enabled with the value of the minimum linear flow programmed in the low flow warning.
- 16.5. **Maintenance expired (0x00010) (MAINT)** – Active when the maintenance timer expires.
- 16.6. **Battery operation (0x00020) (BATT)** – Active when the unit is running on battery.
- 16.7. **Low battery (0x00040) (DEAD B)** – Active when the internal battery is low
- 16.8. **Pulse Output Overload (0x00100) (PLS OL)** – Active when the last attempt to output pulses resulted in an overload. The pulse output system is being overloaded and output pulses are being lost. This is due to the pulse output calculation being exceeded (the pulse width is too wide for the number of pulses being asked to be outputted per second).
- 16.11. **Low Flow (0x00400) (LO FL)** – Active when the ratemeter value is below the low flow warning value.
- 16.12. **High Flow (0x00800) (HI FL)** – Active when the ratemeter value is above the high flow warning value.



- 16.15. **Low Temperature (0x04000) (L₀ EP) (w/ T/C option only)** – Active when the ratemeter value is below the low flow warning value. (optional)
 - 16.16. **High Temperature (0x08000) (H₀ EP)(w/ T/C option only)** – Active when the ratemeter value is above the high flow warning value. (optional)
 - 16.19. **Temperature Short (0x40000) (EP SH₀)(w/ T/C option only)** – Active when the ratemeter value is below the low flow warning value. (optional)
 - 16.20. **Temperature Open (0x80000) (EP OP₀)(w/ T/C option only)** – Active when the ratemeter value is above the high flow warning value. (optional)
- Note:** The number following the items listed above can be logically OR'd together to show the number listed in the outer Alarm menu item.

17. Display (d₀ SPL₀)

The display menu allows modification of values that are used to determine the values displayed when the unit is operating normally. Press **SELECT** to enter the display submenu.

17.1. Display upper (UPPER)

The display upper menu is used to select the values to be displayed in the upper portion of the display. The value shown is a list of the currently selected display items. For example, if the number 0000021 is displayed, this means the upper display will sequence through the two values: Total and Grand Total. The sequence is controlled one at a time via **SELECT**. To edit, press **SELECT**. The menu will allow stepping through the eight possible display slots (via the ▲▼ buttons) and give the option to select several display values (via **SELECT**) for each slot. To skip a slot, select skip. Any combination of values and skips are available. The available display values are:

1. Skip
2. Total
3. Grand Total
4. Rate
5. Temperature (w/ T/C option only)
7. Frequency
8. Battery voltage

17.2. Display lower (LOWER)

The display lower menu is used to select the values to be displayed in the lower portion of the display. The value shown is a list of the currently selected display items. For example, if the number 0000053 is displayed, this means the lower display will sequence through the two values: Rate and Battery voltage. The sequence is controlled one at a time via an internal timer. To edit, press **SELECT**. The menu will allow stepping through the eight possible display slots and give the option to select several display values for each slot. To skip a slot, select skip. Any

combination of values and skips are available. The available display values are listed in the Display upper menu item above.

17.3. Display lower time (L0 dLY)

This sets the lower display sequence time. The custom time (the one that shows the batt) is based on seconds. To edit, hold **SELECT**. Once done editing, be sure to press **MENU** to accept the custom selection as the active.

18. Power mode (POWER)

This sets the power mode or operating refresh time. The number displayed on the left is the current power mode. When changing, the new selection is in the bottom left and the number on the right is the number of refreshes per second. No custom value is allowed here.

19. Maintenance (MAI NE)

The maintenance menu allows modification of values that are used to determine operation of the maintenance timer. The maintenance timer is only active when the ratemeter indicates a value above zero. The number displayed at this menu item is the current amount of time that has elapsed on the maintenance timer. When the maintenance timer exceeds the maintenance time value (19.1 below), the maintenance warning is triggered. Press **SELECT** to enter the maintenance submenu.

19.1. Maintenance time (MAI NE)

This sets the value of the maintenance timeout. When the internal maintenance timer exceeds this value, the maintenance timer warning will be triggered (and alarm if enabled). To edit, hold **SELECT**.

19.2. Restart the maintenance timer (RESARTE)

This will restart the maintenance timer to zero.

20. Reset totalizer (RESETE)

This will reset the resettable totalizer to zero.

21. Test (--ESETE--)

The test menu allows observation and testing of the units various inputs and outputs at the basic non-calculated level. Items in this menu are not subject to the calculations present in the normal

operation mode thereby ensuring the unit is operating and connected properly to external equipment. Press **SELECT** to enter the maintenance submenu.

21.1. Warnings {active} (WARN) (N)

The warnings test submenu is used to determine what warnings are currently active in the unit. The value displayed is a hexadecimal representation of all warnings together. To view each warning individually, pressing **SELECT** will allow the ▲▼ buttons to step through all of the warnings. Refer to the Alarms menu item above for a description (and item number) of each warning. There are three additional warnings (that cannot be selected as alarms). They are:

21.1.2. Process defaults (0x00002) – Active when the unit process values were not successfully restored from EEPROM. This usually indicates something has gone wrong with the internal EEPROM storage. These include the totalizer, grand totalizer, maintenance timer, and internal timers/counters. This warning will be cleared when the process values are successfully saved to EEPROM (this occurs every time the menu is entered).

21.1.3. Setup defaults (0x00004) – Active when unit is using the menu system or linearizer table defaults. This usually indicates something has gone wrong with the internal EEPROM storage. When this is active, the menu system should be checked for valid entries. This warning will be cleared when the menu system parameters are successfully saved to EEPROM.

21.1.4. Calibration defaults (0x00009) – Active when unit is using internal calibration defaults. This usually indicates something has gone wrong with the internal EEPROM storage. When this is active, the internal sensor calibration values have been lost. This will cause the sensor readings (temperature and pressure) to be inaccurate and cause calculation errors. This warning cannot be cleared by the user and the unit must be returned to the factory for service.

Note: The number following the items listed above (and those listed in the Alarms menu) can be logically OR'd together to show the number listed in the outer Alarm or Warning menu.

21.2. Serial Number (SER) (AL)

This is the unit Serial number.



21.3. Total edit (EOLt Ed)

This allows the totalizer to be edited in the case of an accidental totalizer reset operation. The U/M is set using the totalizer U/M menu setting above. When the totalizer is edited, the internal partial pulse totalizer is reset. To edit, press **SELECT**.

21.4. Auto-Calibration (EALt brAt ALtEd)

This sub-menu allows automatic calculation of a corrected K-factor based on information from an external calibration run such as from a calibrated vessel to provide automatic K-factor adjustment. UOM for the displayed and actual values are not important as long as they are the same.

21.4.1. Current K (CURR K)

This shows the current K-factor that was entered in 1.2 above. This is form information purposes only. If the Linearizer is enabled, then this will show ~~NEAR~~ instead.

21.4.2. Displayed Value (dI SPLd)

This is the value that was observed on the FML.

21.4.3. Accumulating Prove Mode (PROVE)

Prove mode is used to deliver a known volume of liquid on the fly. Once a known amount of liquid has passed through the flow meter, press **ENTER** to copy this value into the Displayed value. Pressing the **SELECT** button will reset the total. The delivery will use the current K-factor or linearizer as configured in the menu. Prove mode will only show if the displayed value is zero. This menu will affect the running total and grand total values of the unit.

21.4.4. Actual Value (ACTUAL)

This is the actual amount of liquid that was delivered corresponding to the displayed value above.

21.4.5. Error % (ERROR%)

This is the error percent calculated based on the displayed and actual values above.

21.4.6. New K (NEW K)

This is the new K-factor calculated based on the existing K-factor and the above error %. If the Linearizer is enabled, this will not show.



21.4.7. Apply New Value(s) (APPLY)

This is a final confirmation that the user wants the results of this auto-calibration procedure to be made permanent in the unit. If Yes is accepted, then the K-factor calculated above will be copied into the K-factor of the device. If the Linearizer is enabled, then the error percent will be applied to each point in the Linearizer table and then saved.

21.5. Frequency {Flow input} (FREQ)

This item shows the current frequency of the connected flow meter. Holding **SELECT** will show the maximum frequency the unit has ever seen (“M” will show up on the display). This value is not resettable.

21.6. Temperature (TEMPER) (w/ T/C option only)

This item shows the current temperature of the process liquid. Holding **SELECT** will show the current input resistance in Ohms.

21.7. Pulse output test (PULSE)

This allows the user to simulate a pulse output. Press **SELECT** to enter the Pulse Output test mode. Press the **▲▼** buttons to select the number of output pulses desired for the test. Press **ENTER** to begin the pulse output. The number of remaining pulses will be displayed until all pulses are completely outputted. The pulse width from the Pulse Width menu is used for the output pulses. The CONT selection will cause the pulse output simulator to send pulses until stopped. Press **ENTER** to interrupt the pulse output and select a different number of output pulses. Press **SELECT** to exit the Pulse Output test mode.

21.8. 4-20 mA Simulator (SIMULATE LOOP)

This allows the user to simulate the 4-20mA Loop Output. The following selections are available (Press **SELECT** to step through these):

- 4.0mA – The output is set to constant 4.0mA*
- 8.0mA – The output is set to constant 8.0mA*
- 12.0mA – The output is set to constant 12.0mA*
- 16.0mA – The output is set to constant 16.0mA*
- 20.0mA – The output is set to constant 20.0mA*
- UP – The output is increased from 4.0mA to 20.0mA in 0.1mA increments about 4 times a second
- UD – The output is increased from 4.0mA to 20.0mA and back down to 4.0mA repeatedly in 0.1mA increments (and decrements) about 4 times a second

* Note: At any time when the constant outputs are selected, the output can be increased or decreased by pressing the ▲▼ buttons.

* Press **ENTER** to exit the Loop Output test mode.

21.9. Battery voltage (bAtE V)

This is the current battery voltage in volts.

- L – Indicates the unit is running off of the Lithium battery input.
- E – Indicates the unit is running off of external power. This may be External DC or Loop power. When E is present, the battery indicated above is being used as a backup power source and will become active automatically if the External power source is removed.

21.10. Test LCD (tStELCd)

When **SELECT** is pressed, every segment of the LCD will illuminate.

21.11. Device ID (dEV ID) (optional)

This is the device id used for serial communications.

21.12. Store parameters #2 (PAR2St)

This allows the menu parameters to be stored in a secondary location. The purpose of this is to save the menu parameters in a safe location to allow menu parameters to be modified without fear of losing the current settings. Use the Service menu to restore the menu parameters from this second location.

21.13. Store linearizer table #2 (LI N2St)

This allows the linearizer table to be stored in a secondary location. The purpose of this is to save the linearizer in a safe location to allow the linearizer table to be modified without fear of losing the current values. Use the Service menu to restore the linearizer table from this second location.

21.14. Code version (CdE)

This displays the current code version.

21.15. Reboot (REbSt)

This allows the unit to be rebooted without removing the power. Rebooting is necessary to enter the Service menu. A warning menu of Lose Parameters (LOSE PARAM) will be displayed warning

that all changed parameters within the menu system will be lost if the system is rebooted. To avoid losing anything changed, answer no and exit the menu. This will save the menu parameters. Then re-enter the menu and proceed directly to the test-reboot item. The system will reboot with no loss of menu parameters.

22. Lockout code (LOCKOUT)

The lockout code displayed is the code that must be entered to enter the menu system or the Service menu. If the lockout code is all zeros, then the lockout system is disabled and the menu system may be entered without a lockout code. To change the lockout code, press **SELECT**.

Service Menu

The service menu is used to manipulate a few global settings for the FML250. To enter the service menu, perform a reboot (in the menu under test) or remove and reapply all power. While the unit is starting up, some of the segments on the display will rotate. During this animation, press and hold the **MENU** button. Once the menu is seen, release the **MENU** button. If there is a lockout code entered in the main menu, then it must be entered next. If the lockout code is unknown, the factory can be contacted for a code that will allow the first two items listed below.

The service menu consists of the following items:

1. System Units of Measure (SYSTEM)

This allows the System U/M to be either American or Metric. This setting affects the following menu items:

Value	American AMERICAN	Metric METRIC
K-Factor(s) (pulses per)	Gallons	Liters

When changing the System UOM, two more questions will be asked:

- **Load system (LOAD SYSTEM)**

This allows the System U/M to be applied to other user items in the menu. This affects the following menu items:

Value	American	Metric
Total & Rate	Gallons	Liters
Temperature (all places)	Fahrenheit	Celsius

- **Store configuration (STORE CONFIG)**

This allows the updated values in the previous load system U/M's to the active menu system. This is equivalent to the normal save upon exiting the menu system.

2. Load safe (SAFE LOAD)

This overwrites the entire menu system with factory defaults (also sets the lockout code to 000000).

3. Load parameter #2 (LOAD PARAM2)

This allows the menu system values to be restored from the second parameter storage location thus making them active.

4. Load linear #2 (LOAD LINE2)

This allows the linearizer table to be restored from the second storage location thus making it active.

Main Menu Flowchart

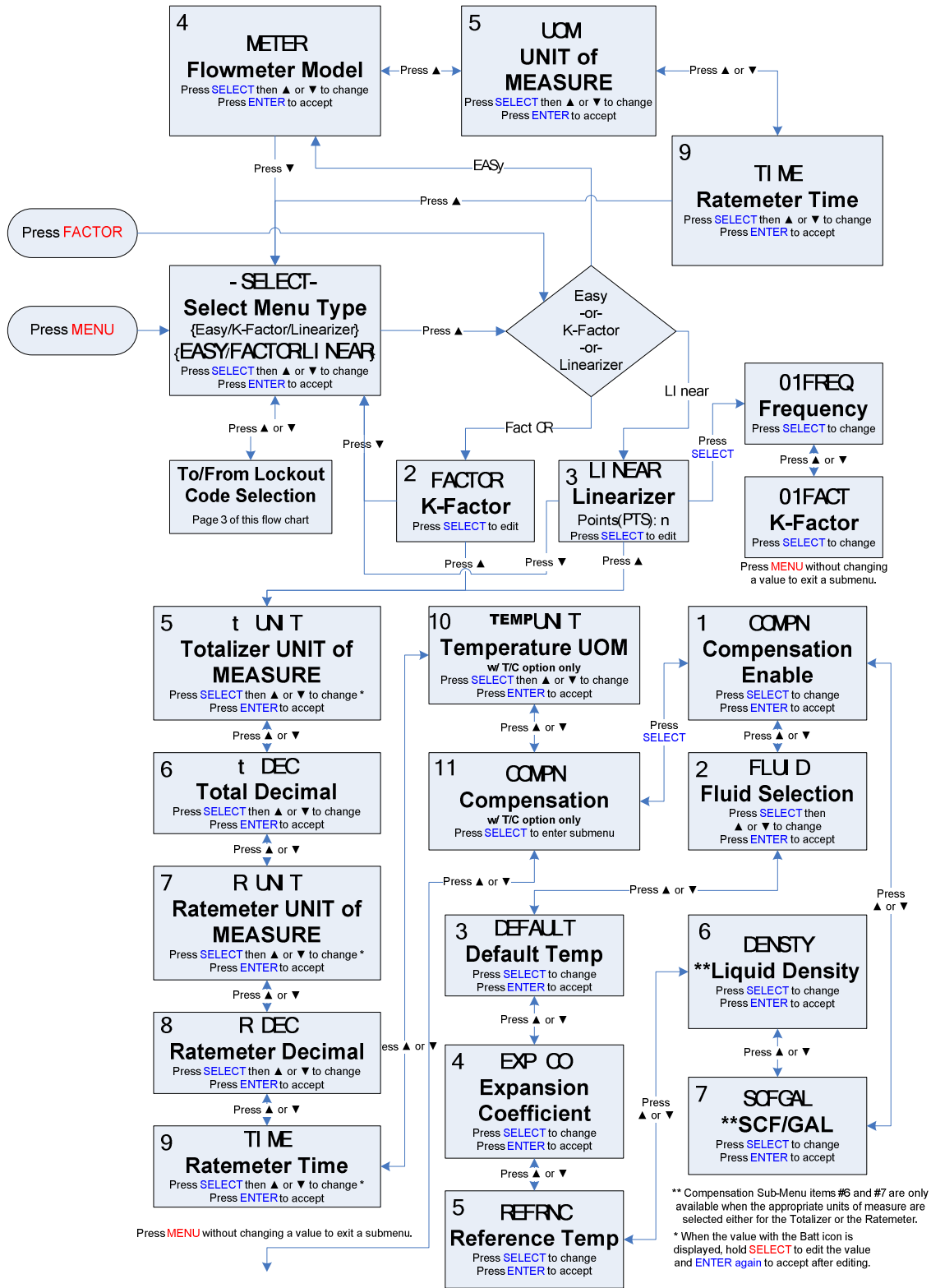

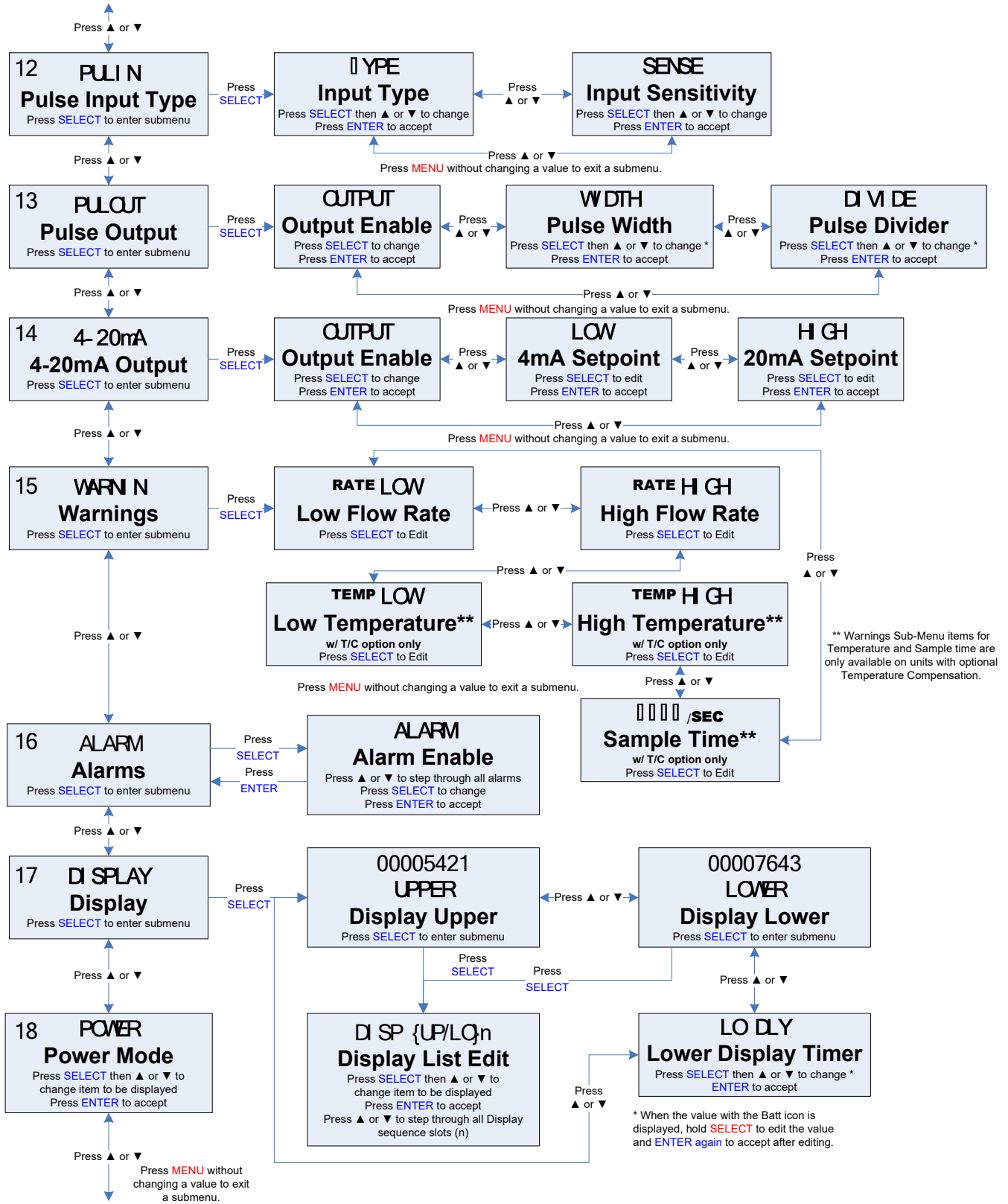

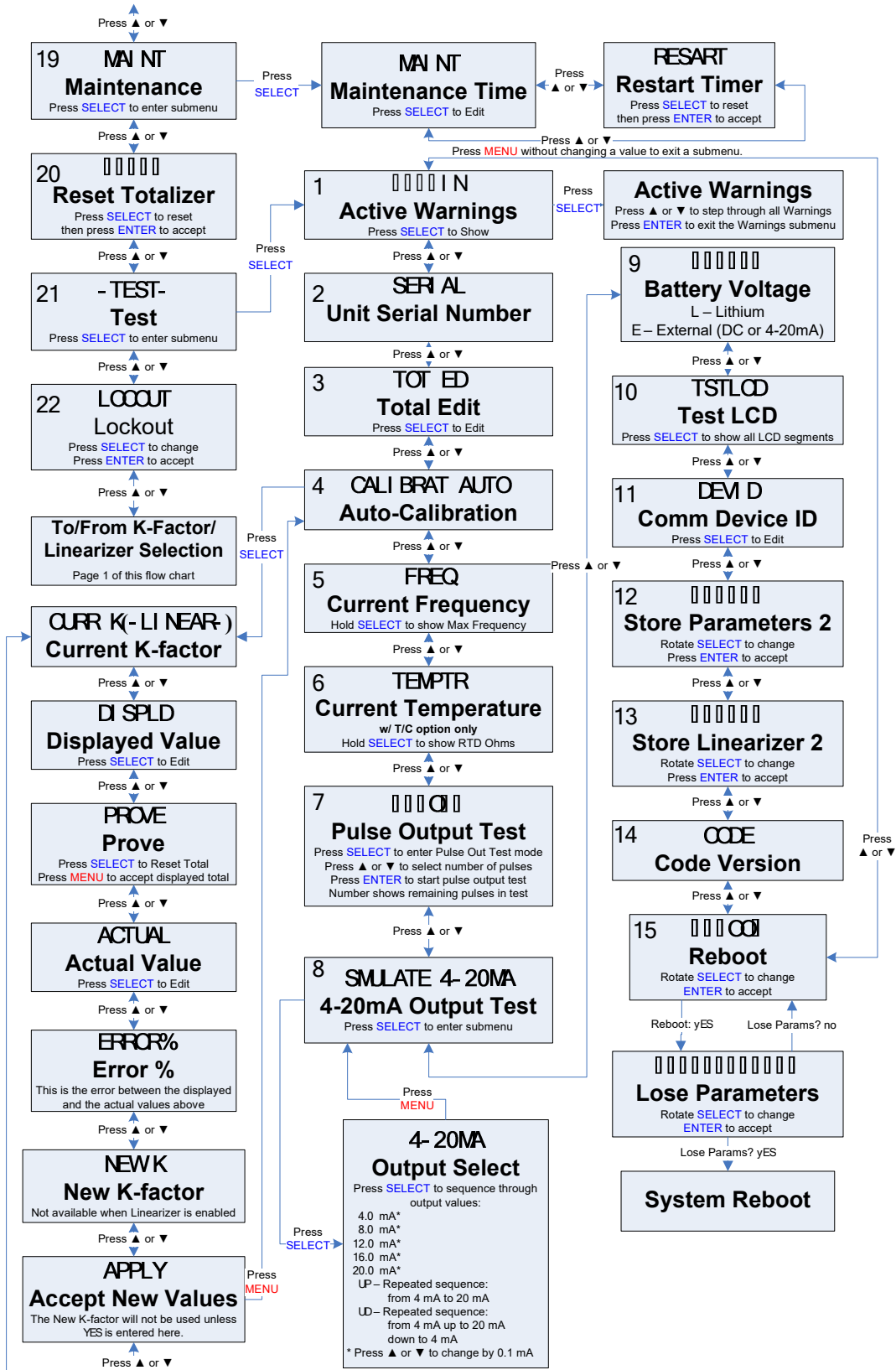

Editing a Number

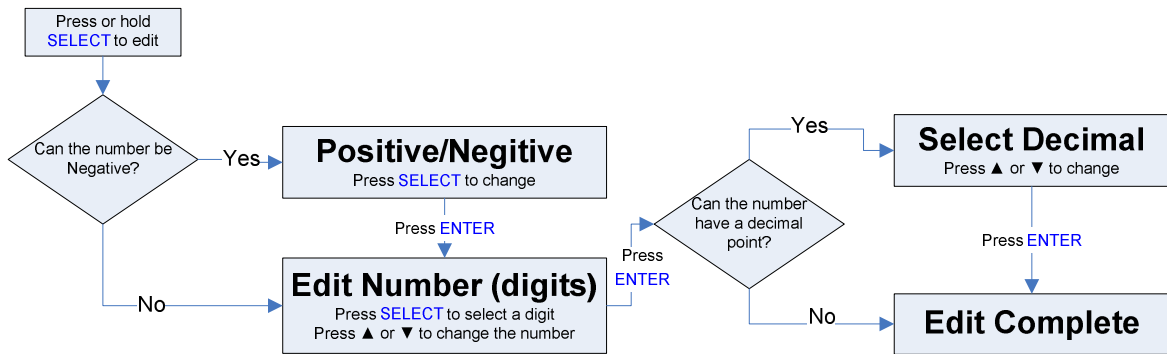

Fluid Properties

Liquid	Reference Temp (°R)	Coefficient of Thermal Expansion (1/°F)	Density (LB/GAL)	SCF/GAL
AIR	141.87	0.0016262	7.293611	97.292
AMMONIA	431.47	0.0005704	5.698802	0
ARGON	157.07	0.0014861	11.615503	112.482
CO2	449.67	0.0012609	8.733752	74.04
ETHYLENE	332.17	0.00068257	4.556502	0
FUELOIL2	519.67	0.0000885	7.8843	0
GASOLINE	519.67	0.0003703	6.25625	0
HELIUM	7.57	0.00011477	1.22205	102.15
HYDROGEN	27.47	0.0007259	0.5907	113.533
KEROSENE	519.67	0.0002681	6.923316	0
METHANE	200.97	0.0010523	3.539861	94.377
NATL GAS	200.97	0.0010523	3.539861	0
NITROGEN	139.27	0.0014917	6.742847	93.1358
NX-19	200.97	0.0010523	3.539861	0
OXYGEN	162.27	0.0013458	9.519392	115.022
PROPANE	519.67	0.0007178	4.233797	133.405
WATER	519.67	0.0001015	8.337656	0

Revision History

Revision	Description	Date
A	Initial Release for UFM	6/30/17

