

## SMVI Intelligent Control Valve



### Design Features

- Improved high-precision two-way metering valves in aluminum or 316 SS for gas/liquid applications.
- Four different control modes and multiple analog interfaces are supported to accommodate the variety of customer applications.
- Standard digital RS-485 interface implemented using galvanically isolated RS-485 transceiver with high common-mode transient immunity allows direct digital communication with PLC or PC and provides access to all configuration and process variable parameters.
- ASCII commands set, free Communication and Configuration software, and LabVIEW Driver\*.
- Eliminates problems associated with solenoid designs, such as coil heating and electromagnetic hysteresis.

## General Description

A line of improved electronic two-way metering needle valves is presented. A high-precision linear stepping motor actuator drives the valve spindle. The standard resolution of the stepping motor actuator-driven needles is 0.000125"/step. In micro-stepping mode, the resolution is 0.0000078125"/step.

### The valve can be controlled using one of the four modes:

- **Analog Interface** (0-5Vdc, 1-5 Vdc, 4-20mA, 0-10Vdc\* options are supported). The valve opening is linearly proportional to the control analog signal in this mode.
- **Digital RS-485 Interface** (via optically isolated transceiver using proprietary ASCII commands set). In this mode, the user can control the valve by sending the command with the desired valve opening position expressed in % of valve full opening (0.00 to 100.00% with 0.01% resolution).
- **Direction / Speed** (legacy SMV valve proprietary mode). In this mode valve is controllable using digital TTL (low active) "Direction" and analog (0-5Vdc, 1-5 Vdc, 4-20mA, 0-10Vdc\* options are supported) "Speed" signals.
- **Step Clock / Direction**. In this mode, the valve is controllable using digital TTL (low-active) "Step" and "Direction" signals. With each falling edge on the "Step Clock" input, the valve needle will move one step to close or open direction based on the logic level applied to the "Direction" input.

Low differential pressure valves may be operated continuously (100% duty cycle). When de-energized, the valves stay in the same position. Advantages over electromagnetic solenoid-operated valves include cool operations, i.e., no control operating problems due to coils heating up, no electromagnetic hysteresis, excellent resolution, and very low differential pressures. The valve control may be overridden with CLOSE and PURGE control signals (TTL low active). To CLOSE the valve, pin 3 on the 9-pin "D"- connector must be connected to GND (pin 2). A GREEN light on the top of the valve will indicate a CLOSED valve condition. To PURGE the valve, pin 7 on the 9-pin "D"-connector has to be connected to GND (pin 2). A RED light on the top of the valve will indicate a fully OPEN valve condition. During regular operation, the valve remains in the last position as it is de-energized.

**TABLE 57 - FLOW RATE FOR SMVI**

MODEL NUMBERS	MAXIMUM FLOW RATE (at 20 psi differential pressure, 70 °F)				C <sub>v</sub>	CONNECTIONS	ORIFICE SIZE
	AIR		H <sub>2</sub> O				
	sL/min]	[scfh]	[L/min]	GPM			
<b>SMVI20</b>	200	424	5.6	1.48	0.336	3/8" compression fitting	3/8"
<b>SMVI30</b>	500	1060	14.2	3.75	0.855	3/8" compression fitting	3/8"
<b>SMVI40</b>	1000	2119	28	7.4	0.735	3/4" FNPT	1/2"

**SMVI20**

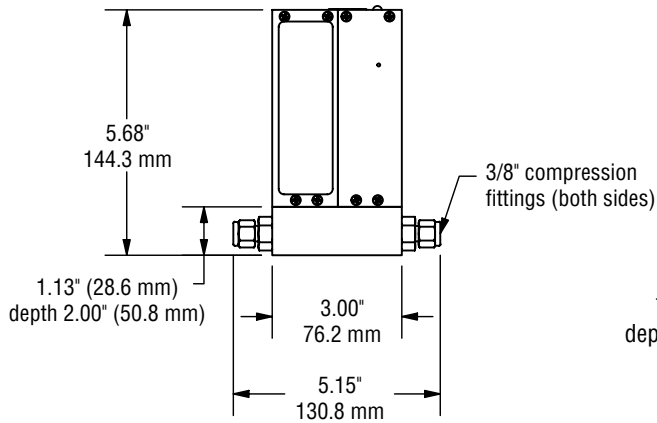

**SMVI30**

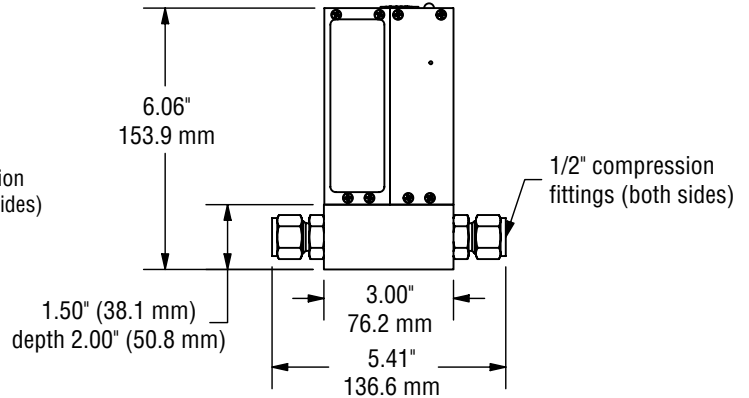

**SMVI40**

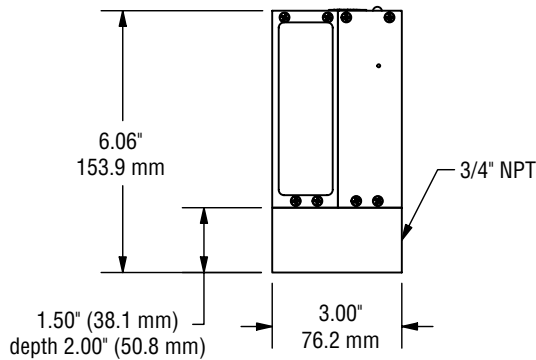

**SMVI40C**

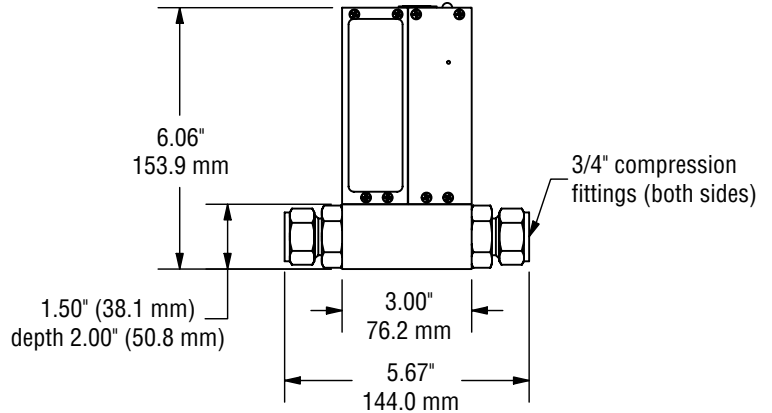

**Table Mounting Holes (Typical)**

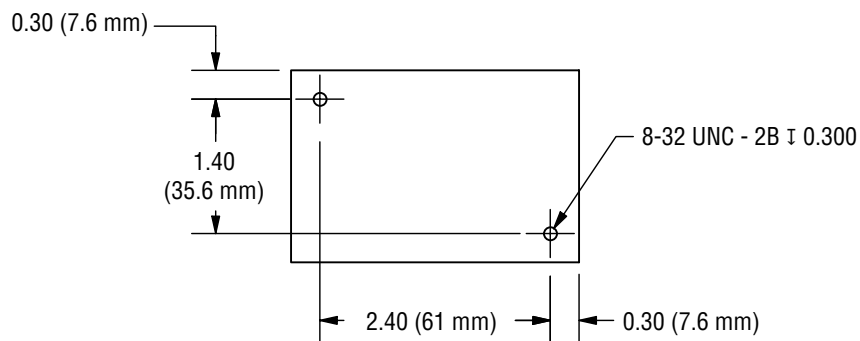

SMVI	MODEL
SERIES	
20	
30	
40	
MATERIAL	
A	Aluminum
S	Stainless Steel
SEALS	
V	FKM
B	Buna®
E	EPR
T	PTFE / FFKM
FITTINGS	
D	3/8" Compression
E	1/2" Compression
F	3/4" FNPT
G	3/4" Compression
POWER	
6	Universal 12 to 24 Vdc
VALVE OPENING CONTROL MODE	
A	Analog Interface (% of opening)
B	Digital RS-485 Interface (all parameters including % of opening)
C	Direction / Speed (legacy SMV valve proprietary mode)
D	Step Clock / Direction
ANALOG INPUT (applicable only for A and C control modes)	
A	0-5Vdc
B	0-10Vdc * (specify during the order, cannot be changed on the field)
C	1-5Vdc
D	4-20 mA

SMVI 30 - S V E 6 - A A

*NOTE: 0-10 Vdc analog input option requires additional jumper installation on the PCB and cannot be selected on the field using user multi-functional button or via digital RS-485 interface. If the 0-10 Vdc option is required, it*

### EXAMPLE: SMVI30-SVE6-AA

Stepping Motor Valve Intelligent 500 sl/min, SS, FKM, 1/2" Compression fittings, universal 12 to 24 Vdc power, Analog Interface, 0-5Vdc.